

Mobile Dock Ramp Instruction Manual

Firstly thank you for purchasing our product, please read the follows instruction, then assemble it, and use it.

Unload:

Use forklift to unload the lift from the container:

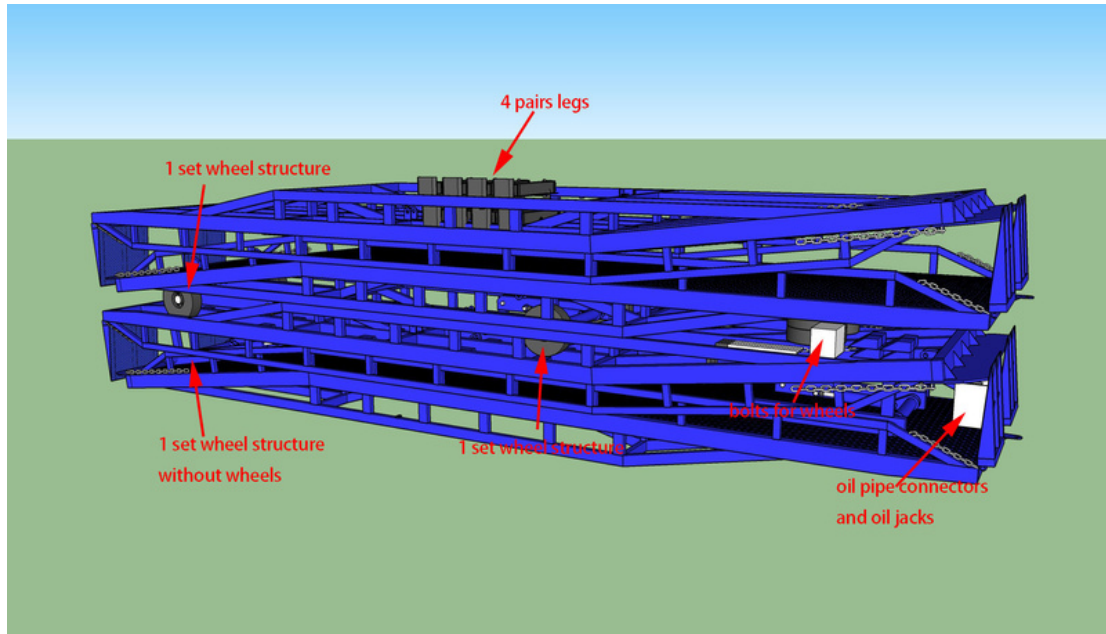

Leg handles, oil jack handles and brakes position as blow, and please note two sets of wheel structures are dissembled:

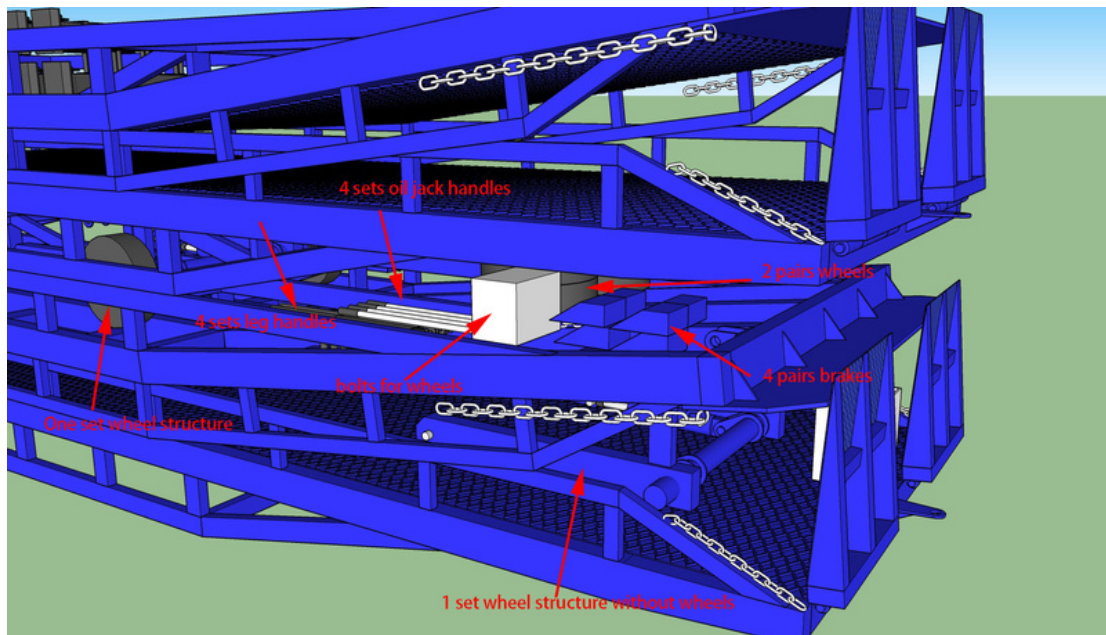

Small parts are all in below box including the 4 oil jacks, and oil pipe connectors:

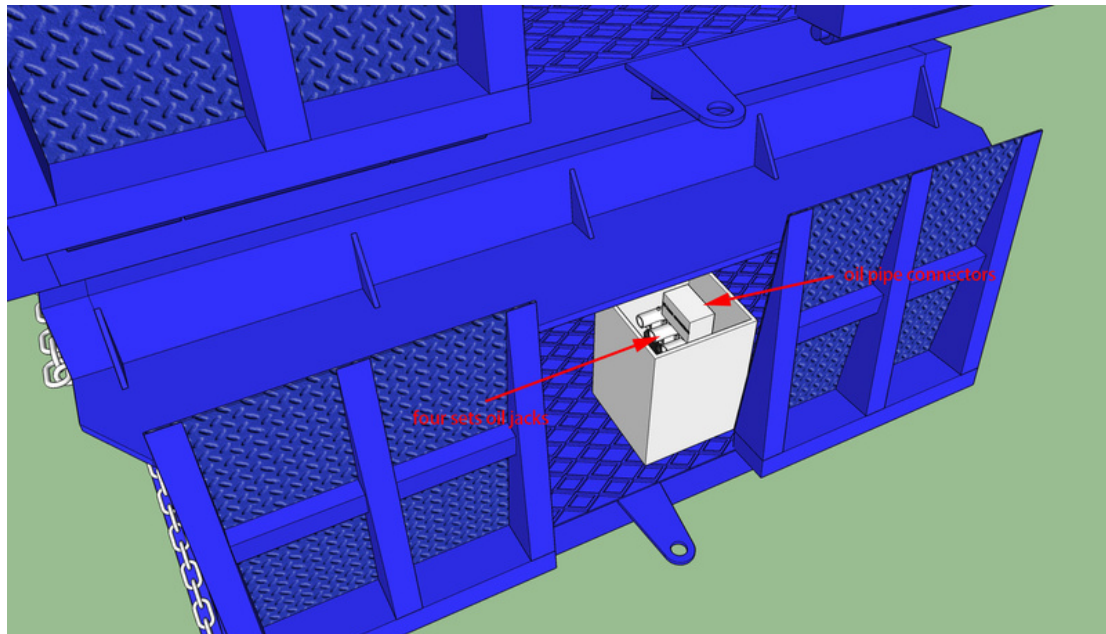

4 sets oil pipes position as below:

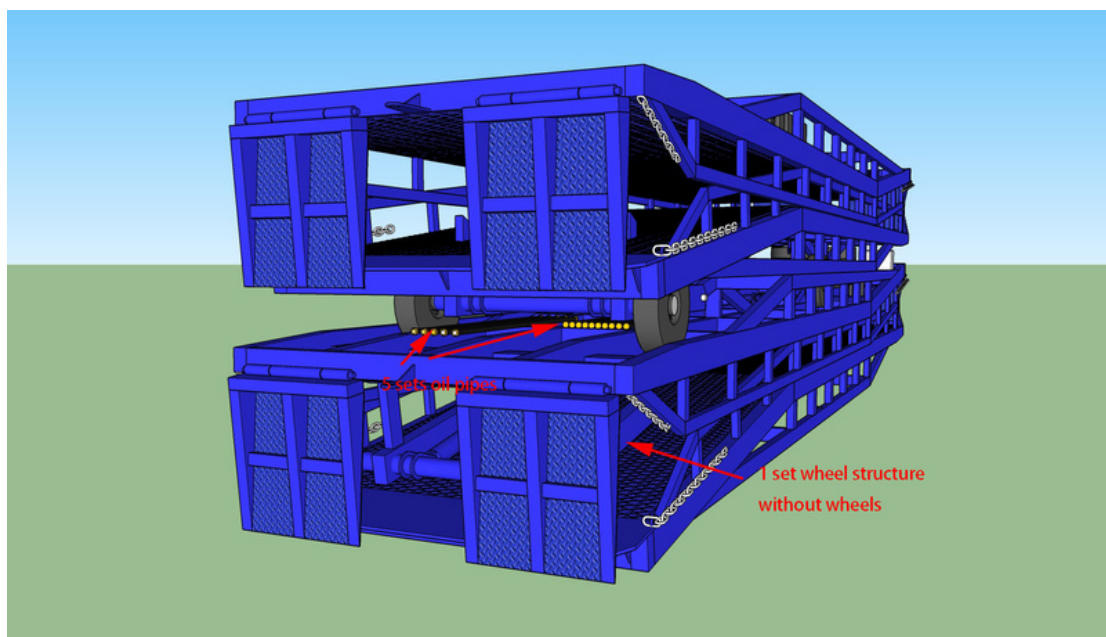

3D drawing link as below, you can open in Chrome, Opera, Foxfire and IE browsers:

Assemble

Put the wheel structure under the ramp and connect by axles. Two longer axles to connect the structure and two shorter axles to connect the hydraulic cylinder:

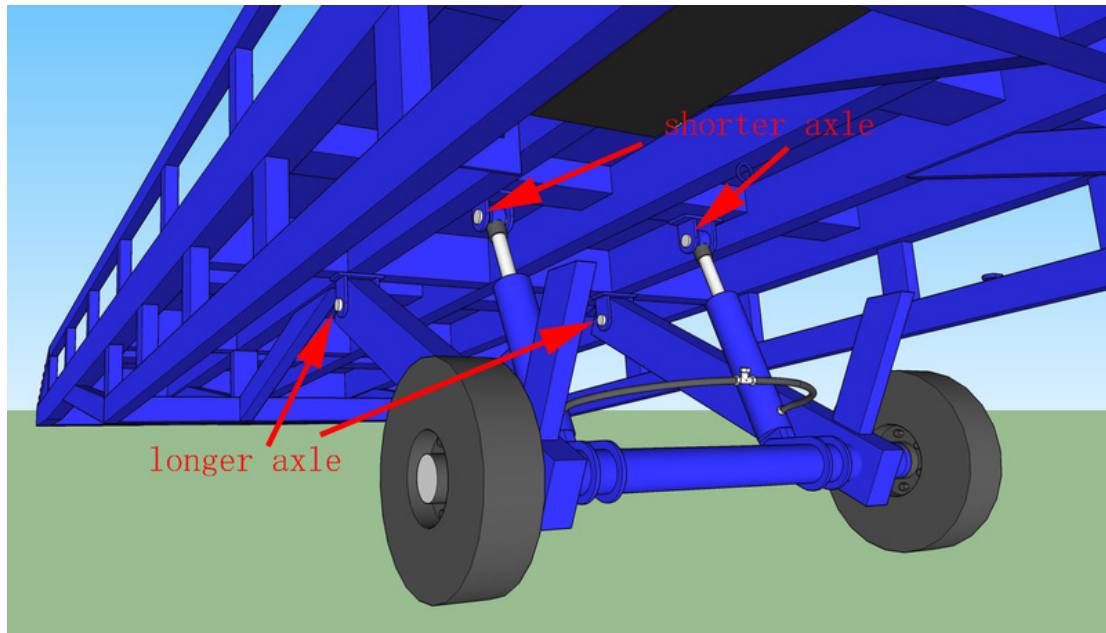

Connect the oil jack by three screws as below:

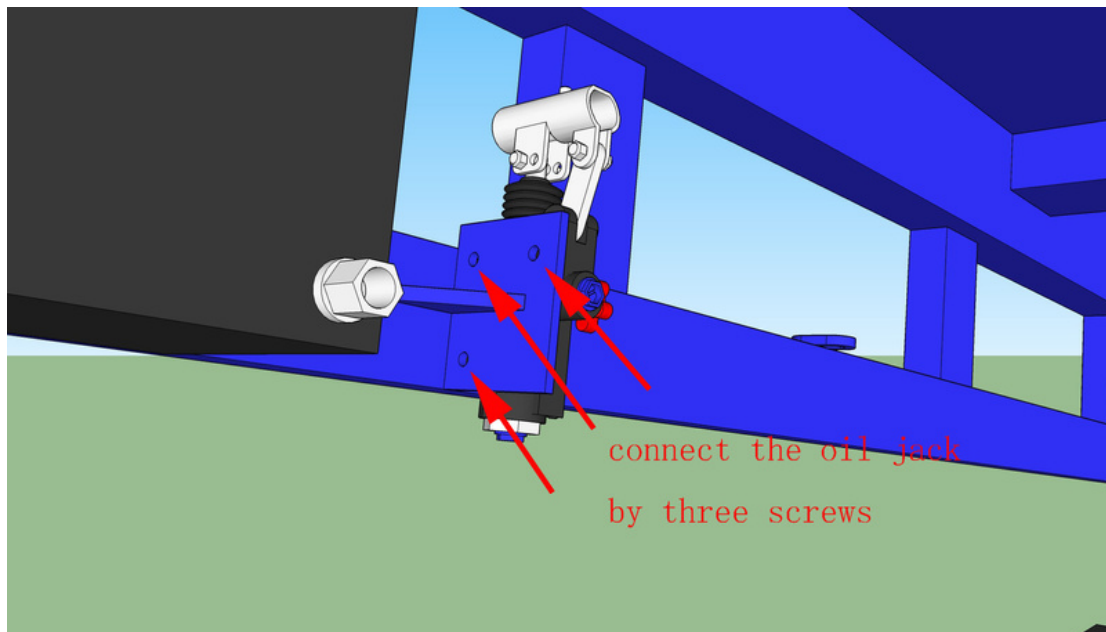

Connect the oil hoses, one longer hose connect the tee from hydraulic cylinder with oil jack outlet. Another shorter hose connect the oil tank with the oil jack inlet :

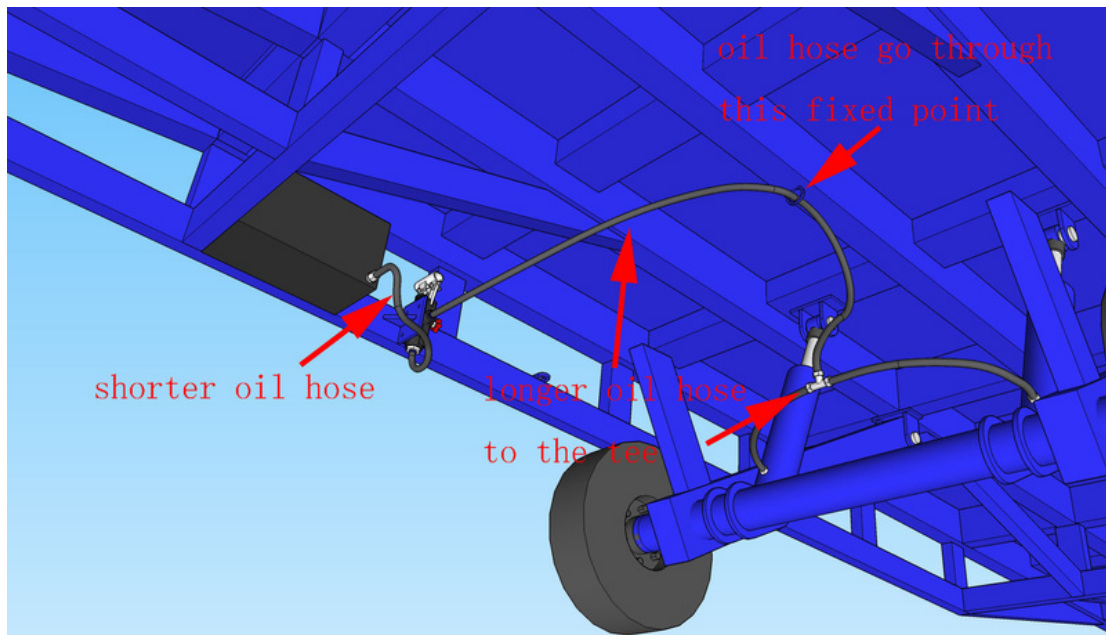

Put the two brakes in right way and put oil jack handle in suitable position as below:

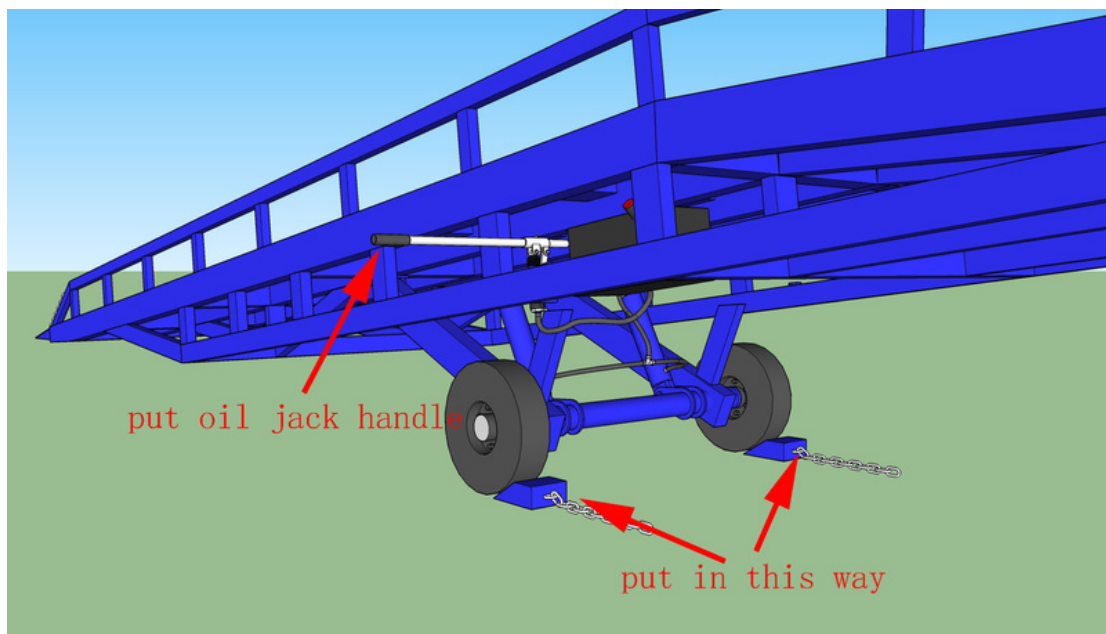

Assemble the legs as below:

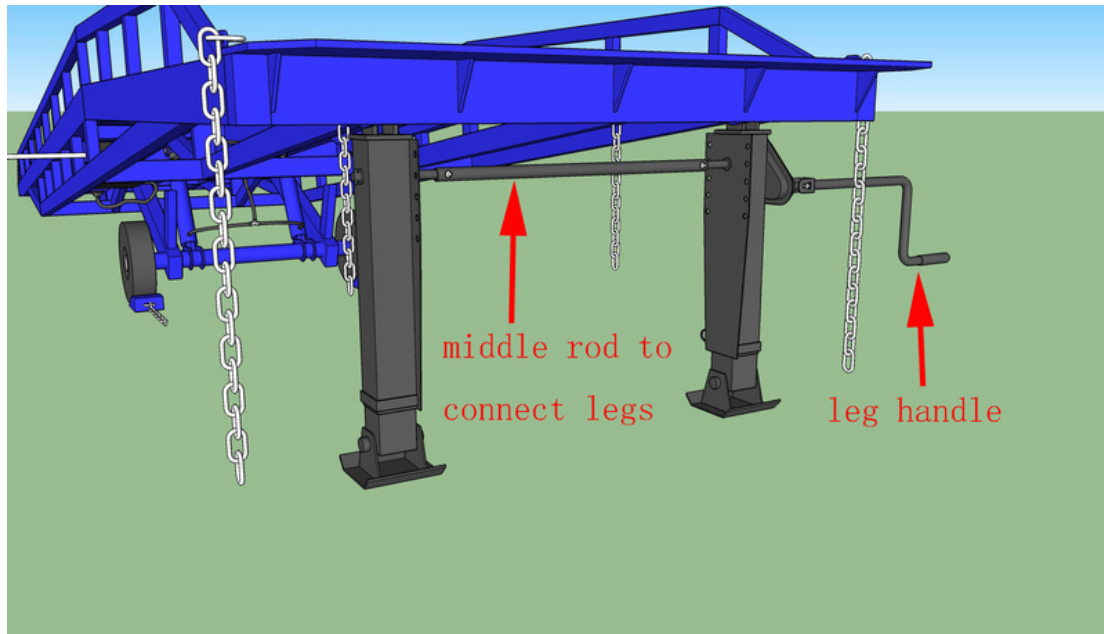

Use

Firstly add the hydraulic oil into oil tank, totally around 10-12 liters, add around 70% of the oil tank volume. If temperature above -10 degree you add 46# hydraulic oil, and if temperature below -10 degree you add 32# hydraulic oil.

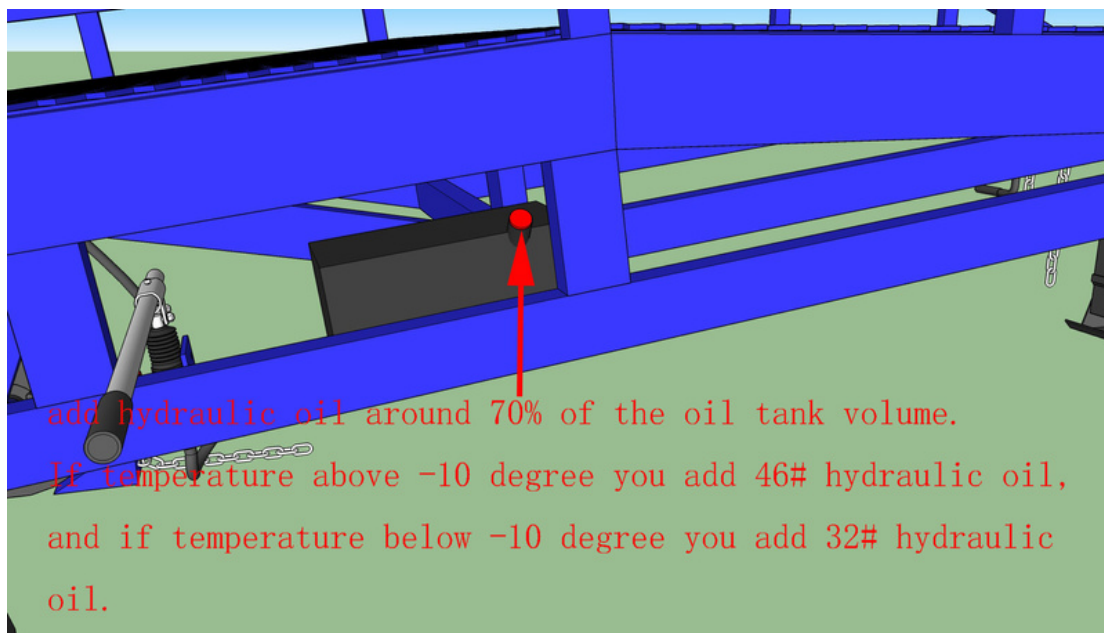

Close the oil release valve, and pump the oil to the cylinder by continuously push the oil jack handle until the ramp front plate higher over the container platform or dock platform:

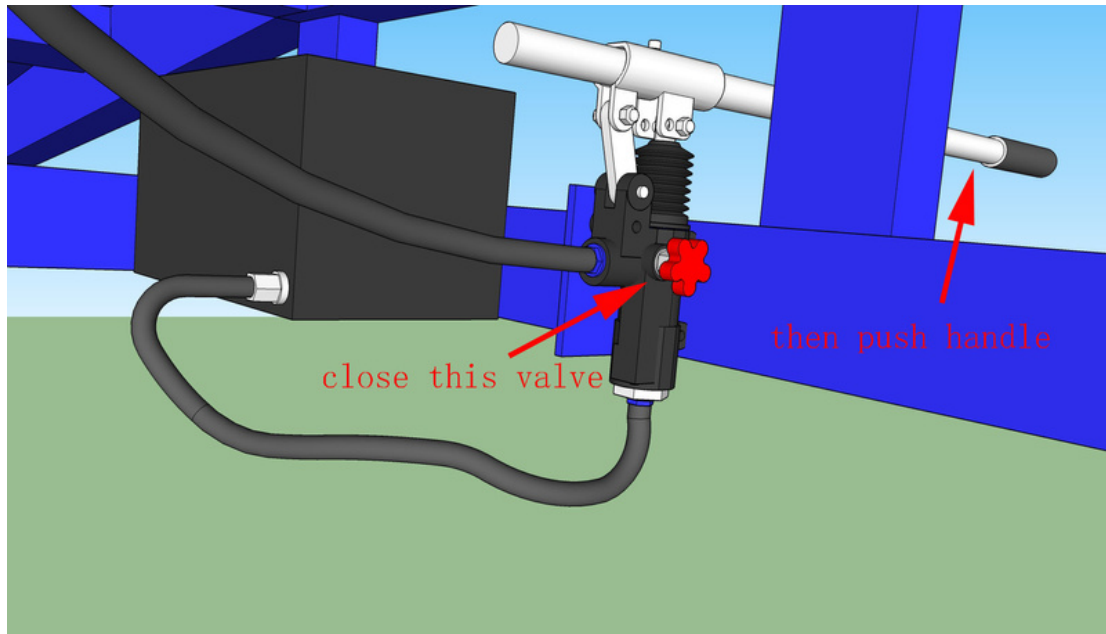

Drive the container truck back to the ramp and let the ramp front plate above container platform. Or move the ramp to dock and let its front plate above dock platform:

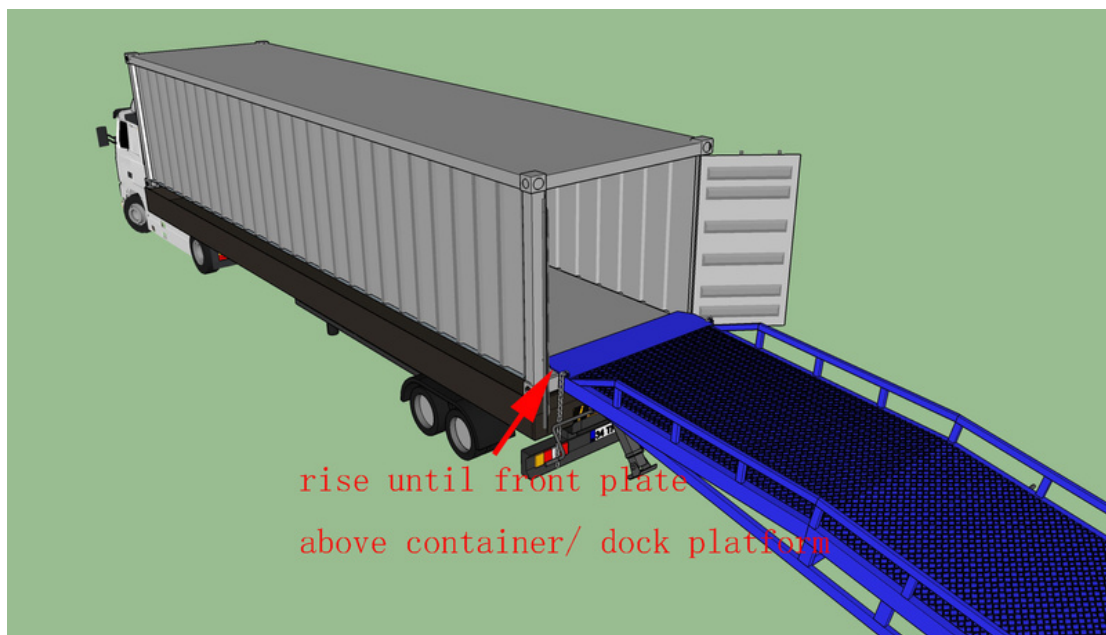

Open the oil release valve and let ramp front plate get down and touch the container/dock platform:

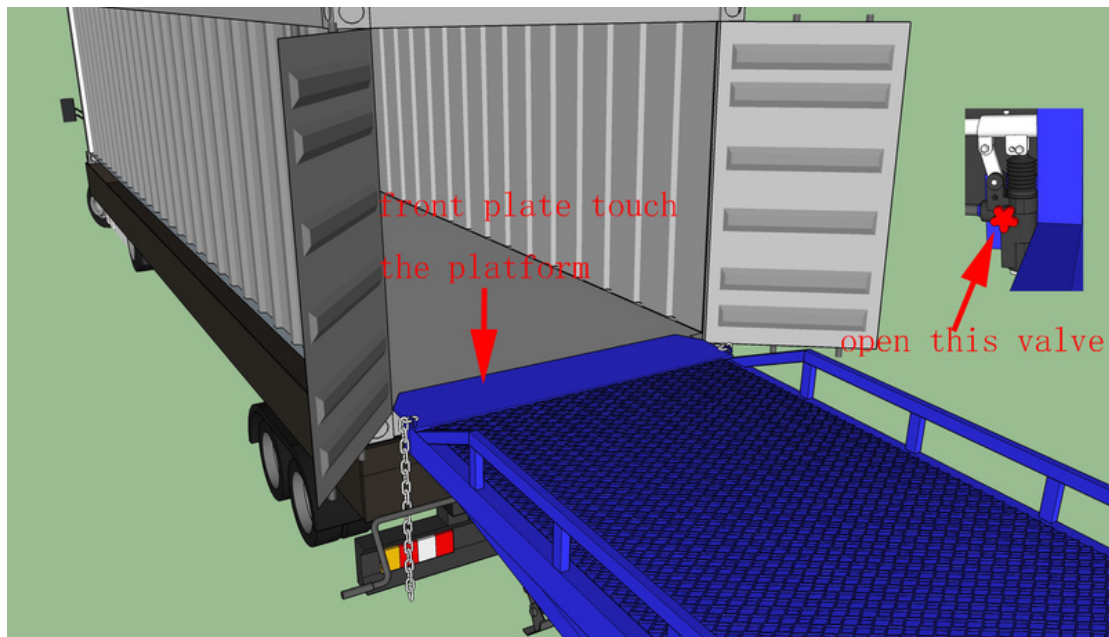

Attach the front steel chain to the truck/dock:



Put down the legs and turn the leg handle until legs slightly touch the ground. If the ground is not even, put some wood under the leg not touch ground.

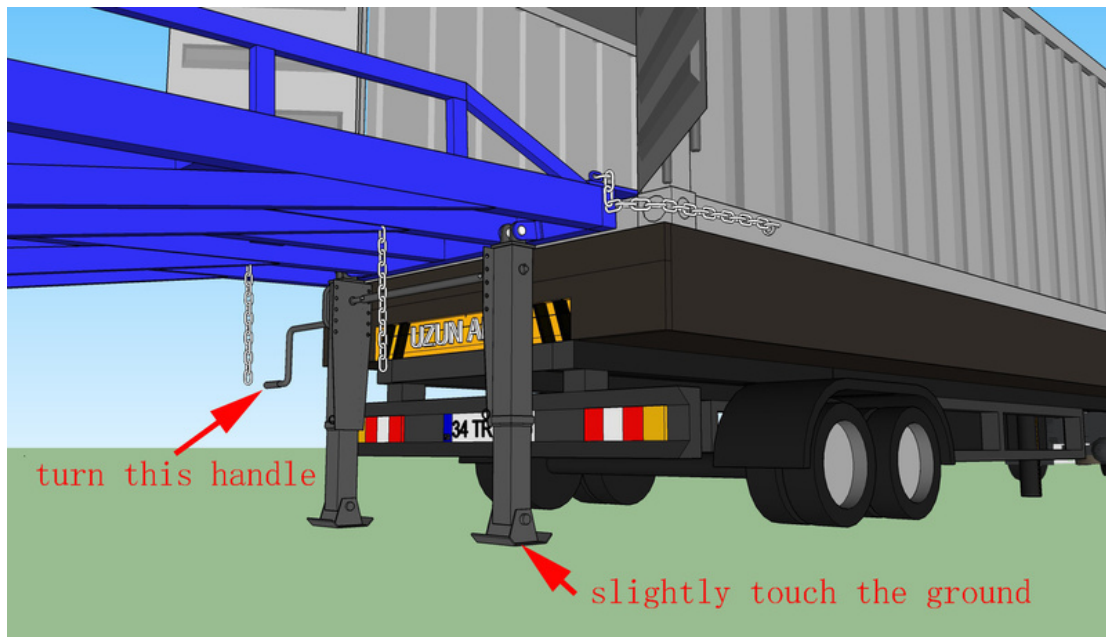

Put the brakes as below direction:

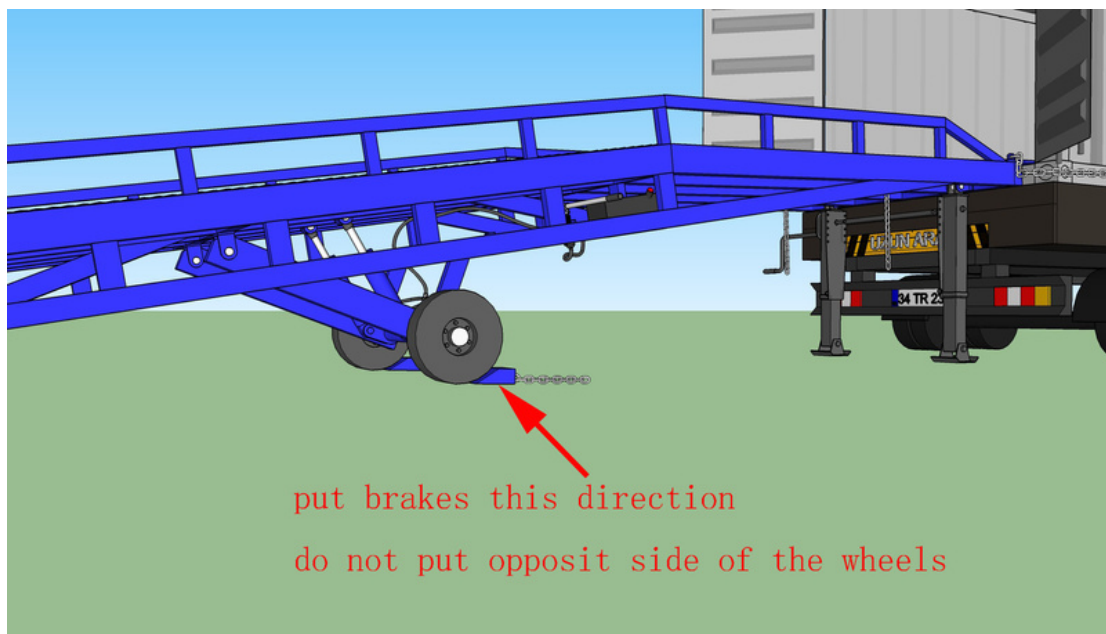

Start to loading or unloading the cargos by forklift. After finished loading or unloading, close the oil release valve and push the oil jack handle and let the ramp front plate rise, then let the truck drive out. Then put back legs, and put the brakes onto ramp body as below:

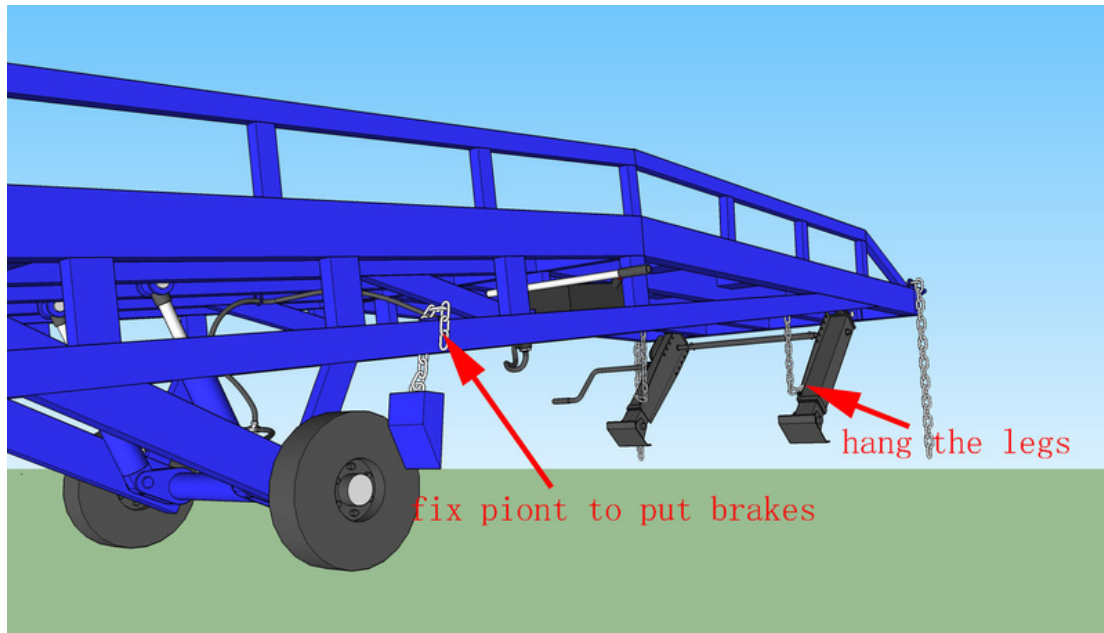

Trouble Shooting

1 The hydraulic oil unit cannot supply hydraulic oil and platform cannot rise up:

reasons	solution
Oil hoses are not connected in the right way	Connect it in right way
No hydraulic oil in oil tank or shortage of oil	Fill in hydraulic oil
Hydraulic oil is dirty	Change the hydraulic oil
Oil release valve opened	Close the valve
Oil hoses leak	Tighten the oil hose connection or change the oil hoses

2 The hydraulic oil cannot return back to the hydraulic oil station and platform cannot get down:

reasons	solution
Oil release valve closed	Open the oil release valve
Oil blocked and cannot return to oil tank	Check the oil hose

Structure of the ramp

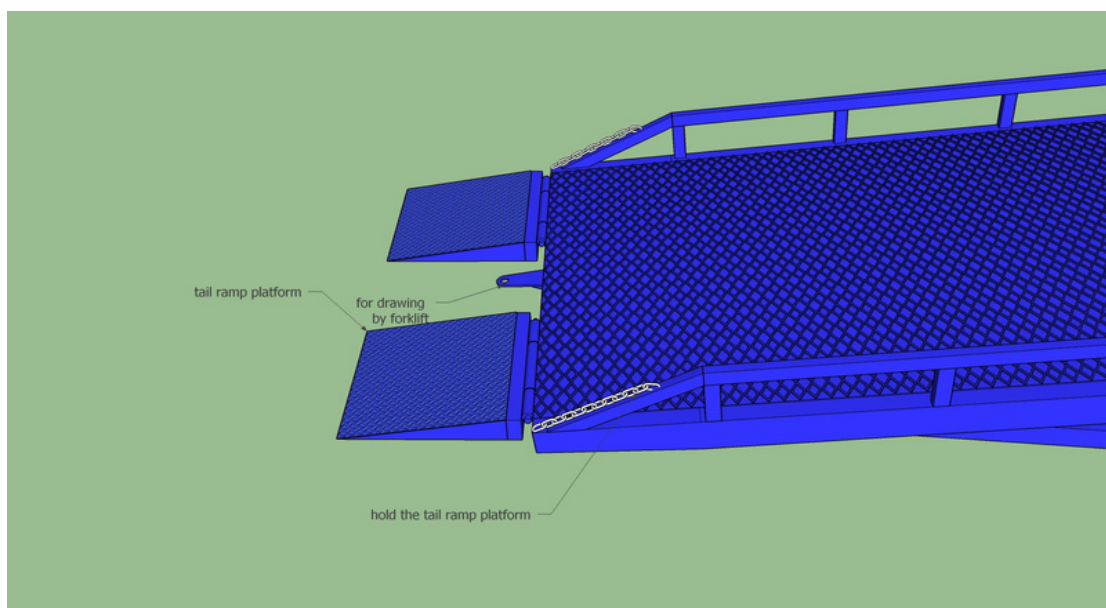
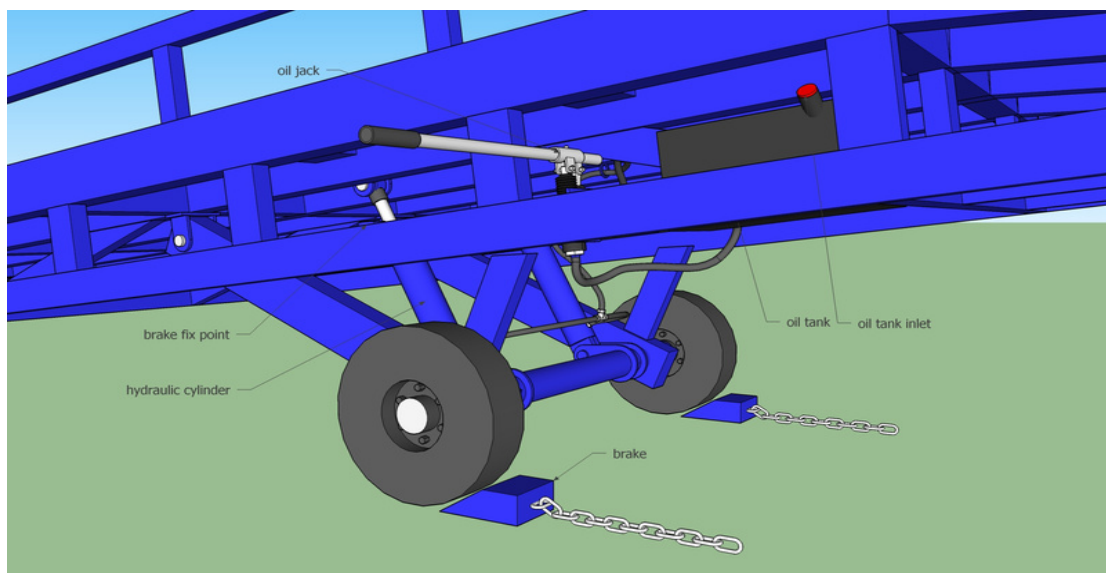
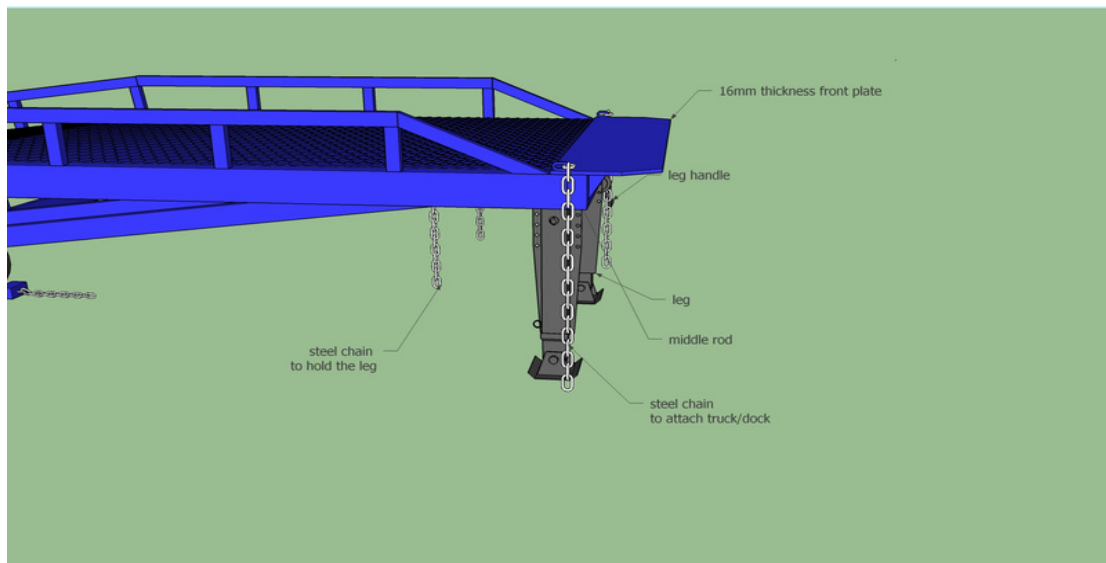

Maintenance

- 1 Exchange the hydraulic oil every half or one year.
- 2 Check the structure every 1 year and to see if they are in good situation.
- 3 Check the oil jack, leg structure every 1 year to see if they are in good situation.

Warning

- 1 Don't under the ramp platform when ramp is in used.
- 2 Don't over load, the rated load is 10000kgs
- 3 Only let the legs slightly touch the ground, the legs not for bearing loading, it is for cushioning the impact when forklift running on ramp. .
- 4 if the ground is not flat, you need to put some woods under legs to adjust the legs height.
- 5 Put the brakes in the right direction rather than in opposite side of wheels.
- 6 The front steel chain must attach to the truck or dock platform when the ramp is in use.