

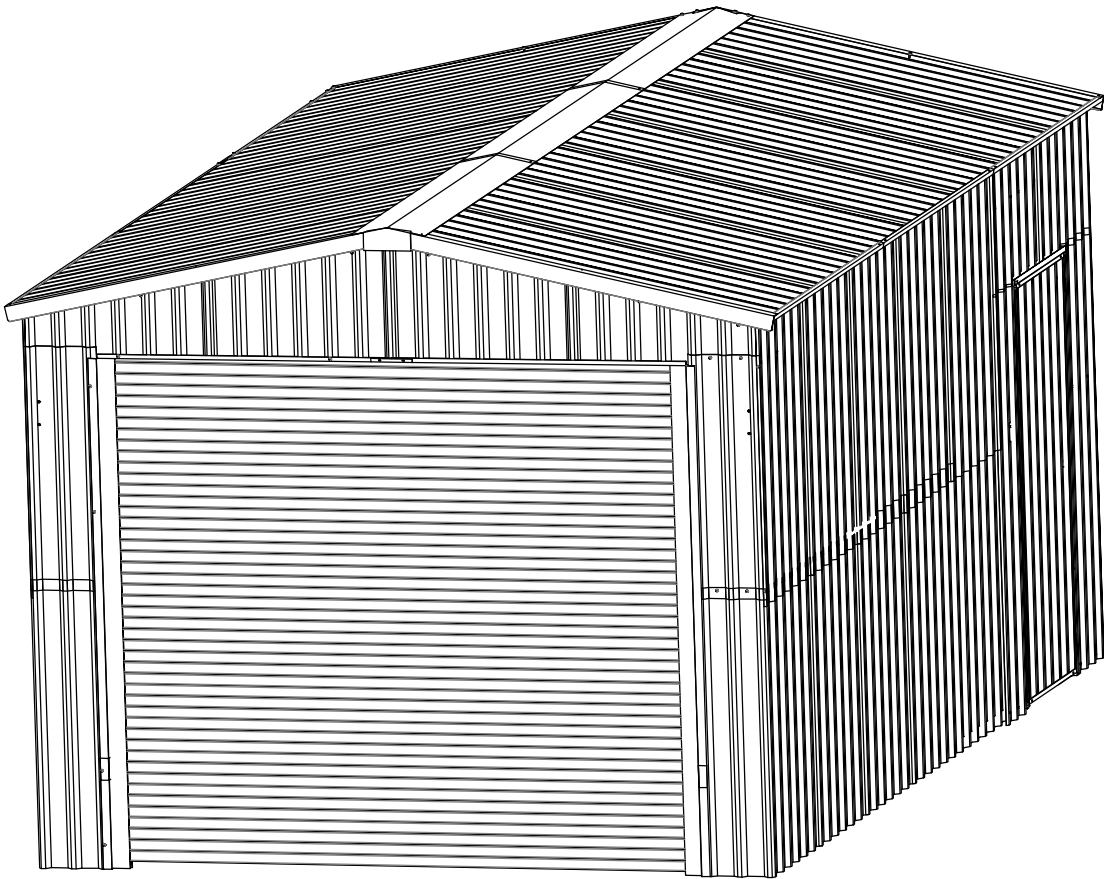





INSTALLATION INSTRUCTIONS

SG1219

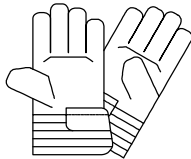

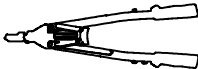
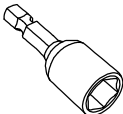
BEFORE YOU START

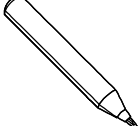
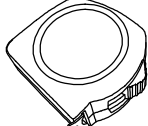
Items Required:





























Tools					
	gloves	Safety Glasses	Shoes	Riveting Gun	Sleeve
Tools					
	Power drill	Screw driver	Pencil	Tape Measure	Ladder

- Clear a working area to allow access on 4 sides. A raised work surface will make assembly easier.
- Please choose a dry and calm day to start assembly. Do not attempt installation in rainy or windy day.
- **Keep roof clear of leaves and snow with long handled, soft-bristled broom. Heavy amounts to snow on roof can damage building, making it unsafe to enter.**
- All parts are identified so when working through the instructions page by page the diagrams show where each part is positioned.
- Before starting, to avoid any accidental injury, we recommend the use of gloves to protect your hands, safety glasses to protect your eyes and shoes or boots to protect your feet.
- Please keep children away from your construction site.
- Most assembly can be completed by one person, assistance may be needed when you reach the erection stage.
- Cleaning should be performed as often as is required to remove any dirt, salt, and pollutants.
- Please note: Some local government authorities have rules & regulations on shed installation and you may need approval to erect this shed.



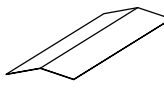













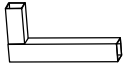











STEPS:

1. Unpack all components from the carton and lay outside your work area and check parts against the part list on the next page.
2. Refer to page "HOW PANELS ARE JOINED".
3. When completed place shed in position and anchor securely to the ground.
4. Clean up all metal pieces, rivets and screws.













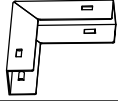

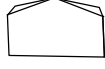

PART LIST

Picture	Name	QTY	Check	Picture	Name	QTY	Check
	PD1	1			P1	28	
	P2	1			P3	1	
	P4	2			PA1	2	
	PA2	2			PA3	1	
	PA4	1			PA5	1	
	PA6	1			PB1	1	
	PB2	1			PB3	1	
	PB4	1			PT1	14	
	FD1	2			FD2	1	
	FD3	1			FDU1	1	
	FDU2	2					
	F2	4			F3	2	
	F4	2			R1	2	
	R2	1			L1	4	
	L2	4			L3	2	

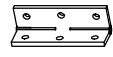
PART LIST

Picture	Name	QTY	Check	Picture	Name	QTY	Check
	JA1	1			JA2	2	
	ZD1	2			ZD2	2	
	A1	2			A2	2	
	A4	2			A5	2	
	A6	10			A7	2	
	A8	1			A9	1	
	A10	8			AC1	8	
	AC2	4			A18	1	
	A19	1					
	MS1	1			MS2	2	
	B1	2			B2	8	
	B3	4			B4	4	
	B5	7			B6	4	
	B7	1			B8	1	
	B9	4					



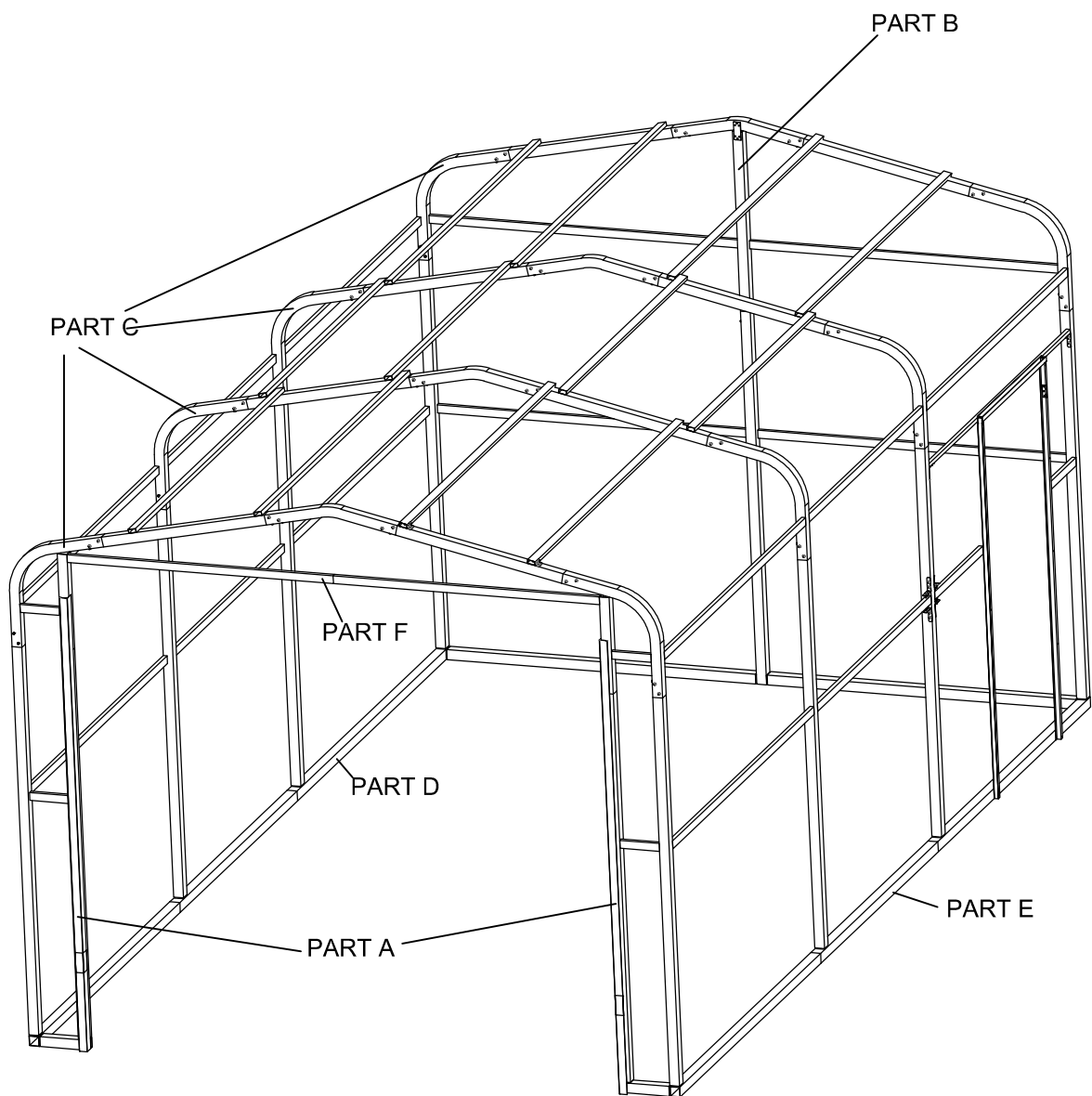

PART LIST

Picture	Name	QTY	Check	Picture	Name	QTY	Check
	J3	5			S12	1179	
	S13	29			C12	4	
	L1A	6			C52	4	
	L3	22			C22	82	
	LG6	2			S11	10	
	C3	16			H1	1	
	C72	10			SH1	2	
	S3	24			UV3	2	
	S7	18			L8	2	
	ROLL UP DOOR	1					

FRAME ASSEMBLY



FRAME ASSEMBLY

	A6	2		A7	2		A8	1		A9	1
	S12	12									

STEP 1

when you install the square tube, it will be much easier to adjust the angel first.

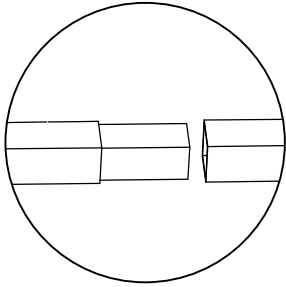

STEP 2

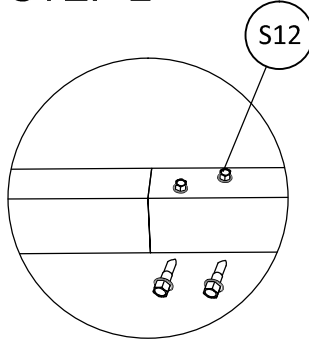

STEP 3

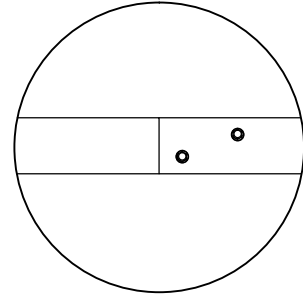



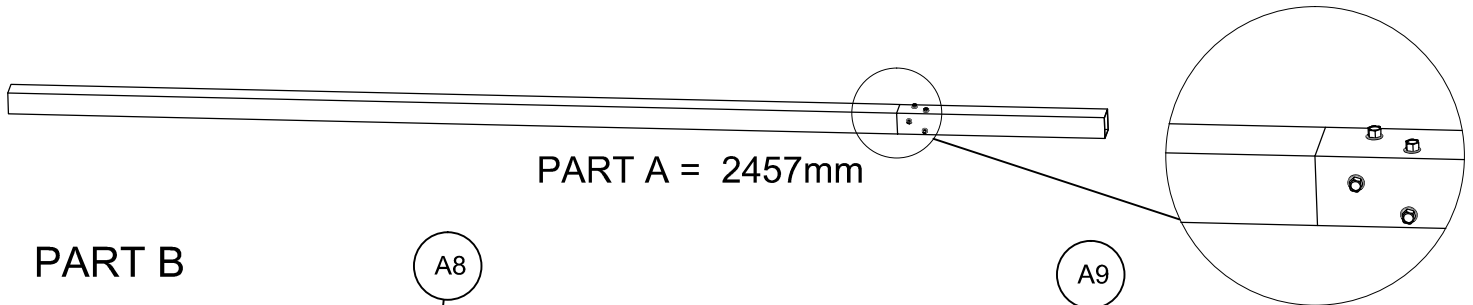

PART A X2

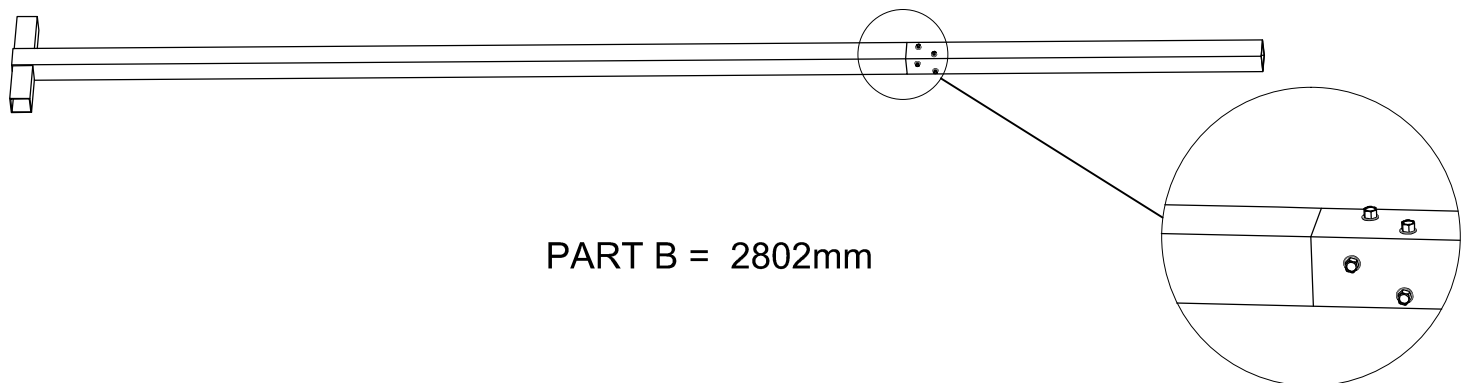
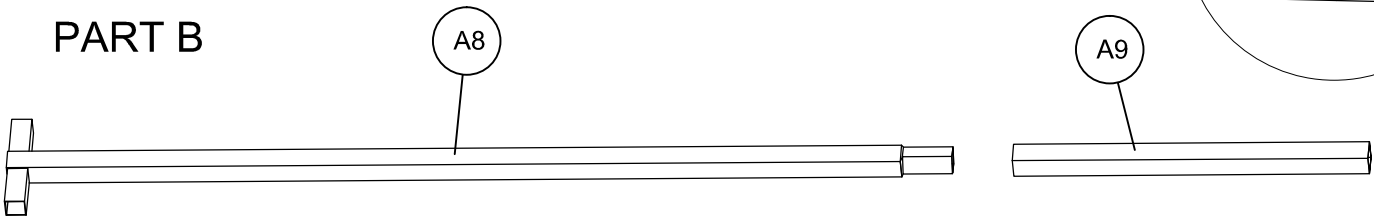

PART B





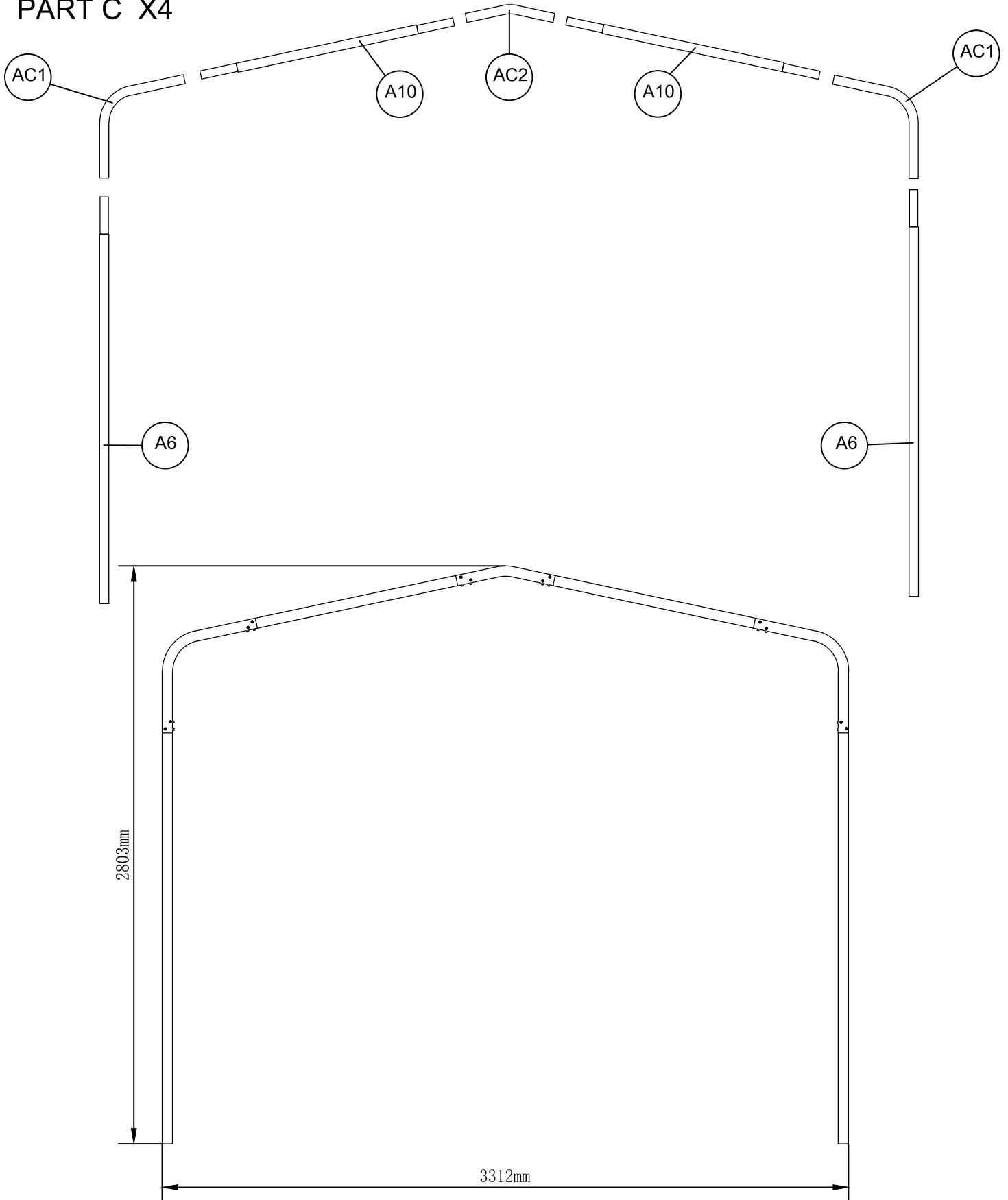

FRAME ASSEMBLY

	A6	8		A10	8		AC1	8		AC2	4
	S12	96									

PART C X4



FRAME ASSEMBLY

	A1	2		A2	2		A18	1		A19	1
	S12	16									

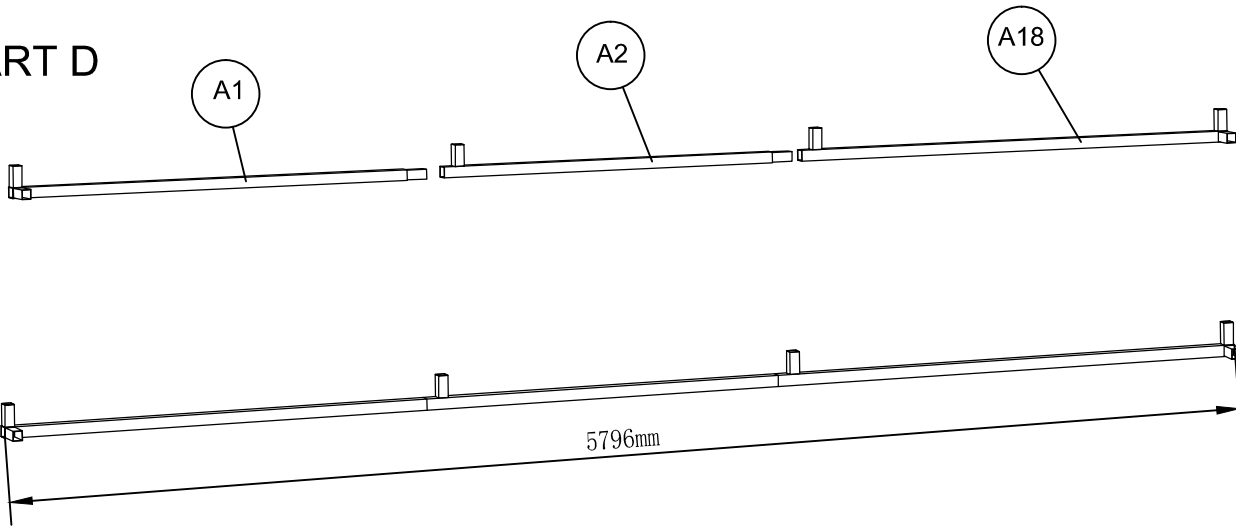

PART D

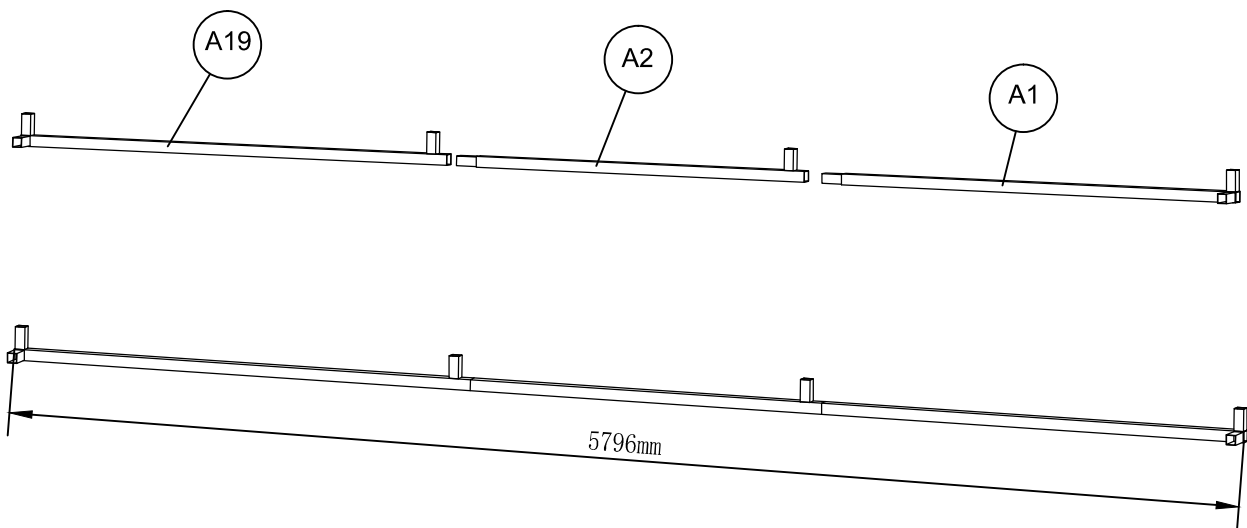

PART E





FRAME ASSEMBLY

	B1	2		C52	1		S12	6
---	----	---	---	-----	---	---	-----	---

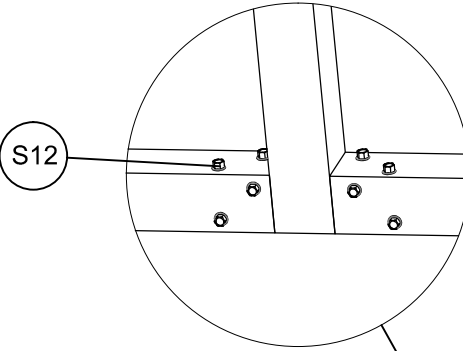
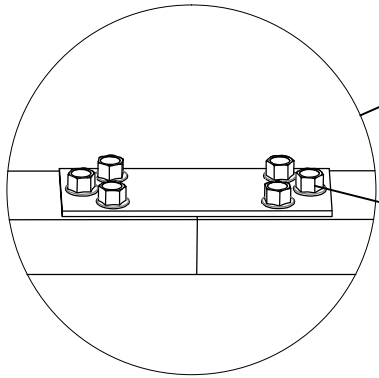
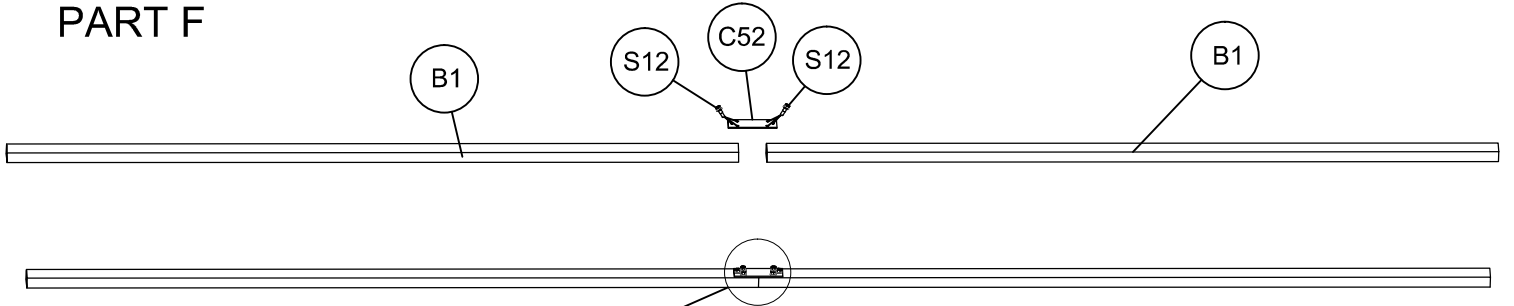

PART F

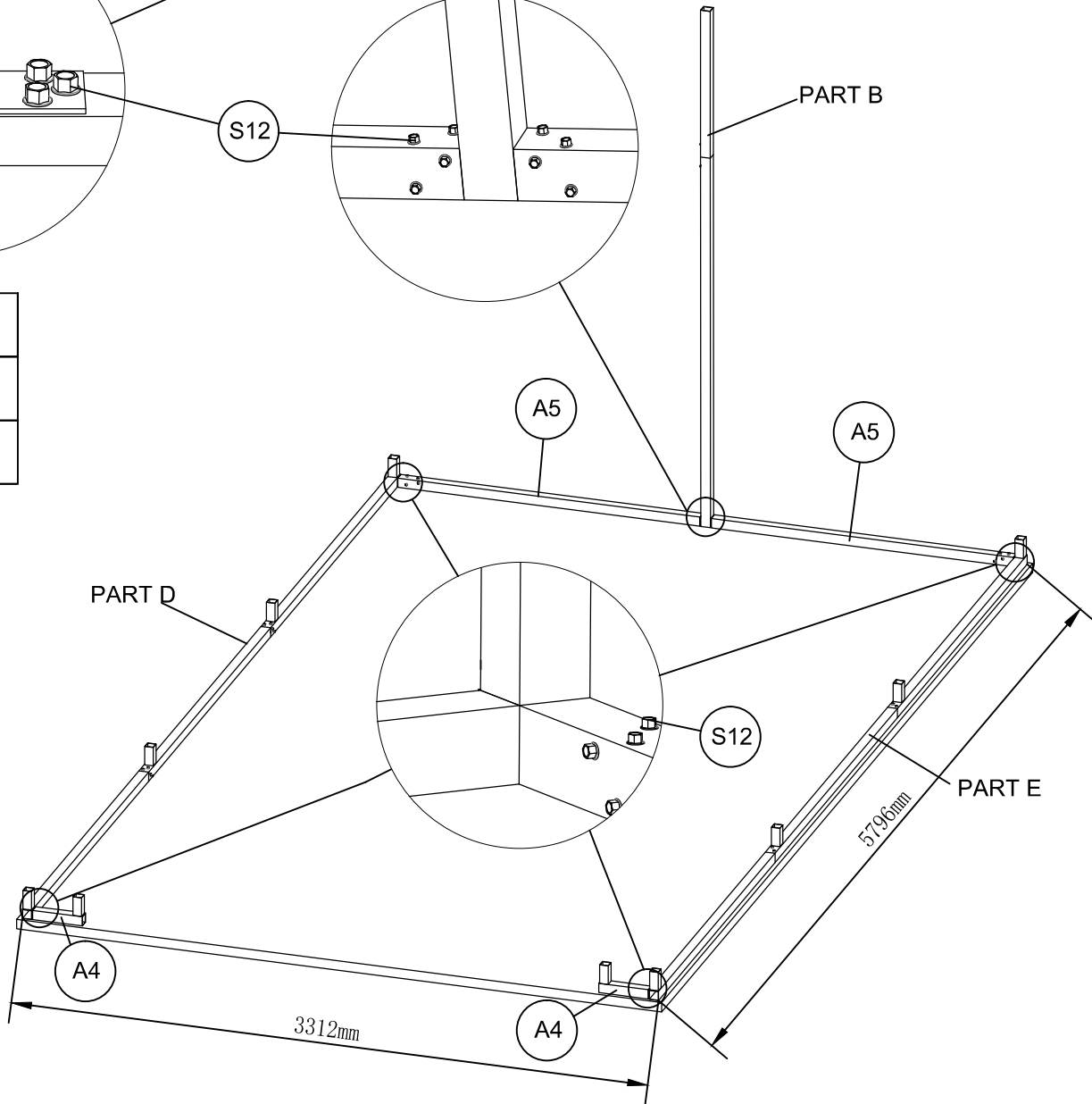

	A4	2
	A5	2
	S12	24



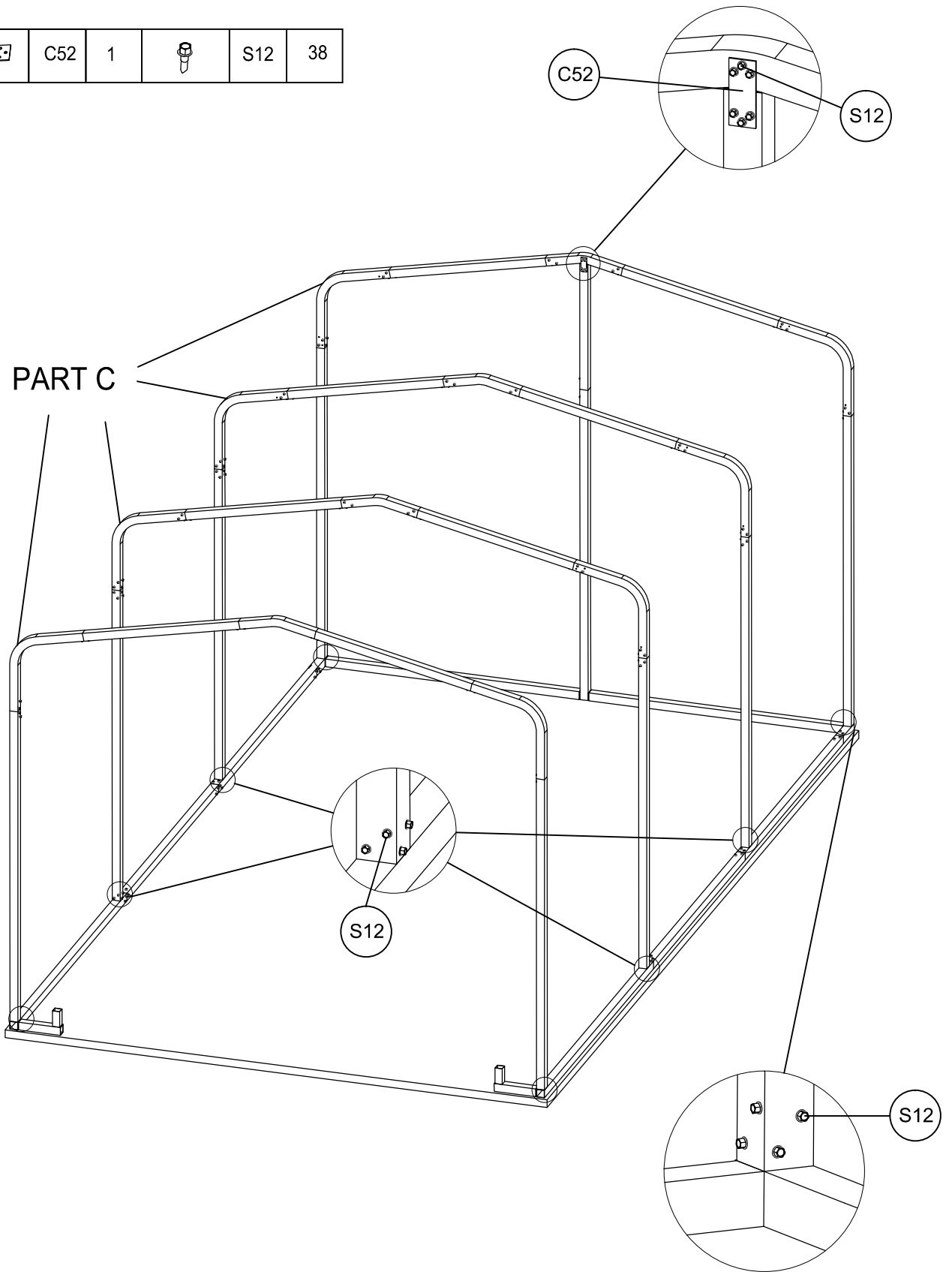

FRAME ASSEMBLY

	C52	1		S12	38
---	-----	---	---	-----	----



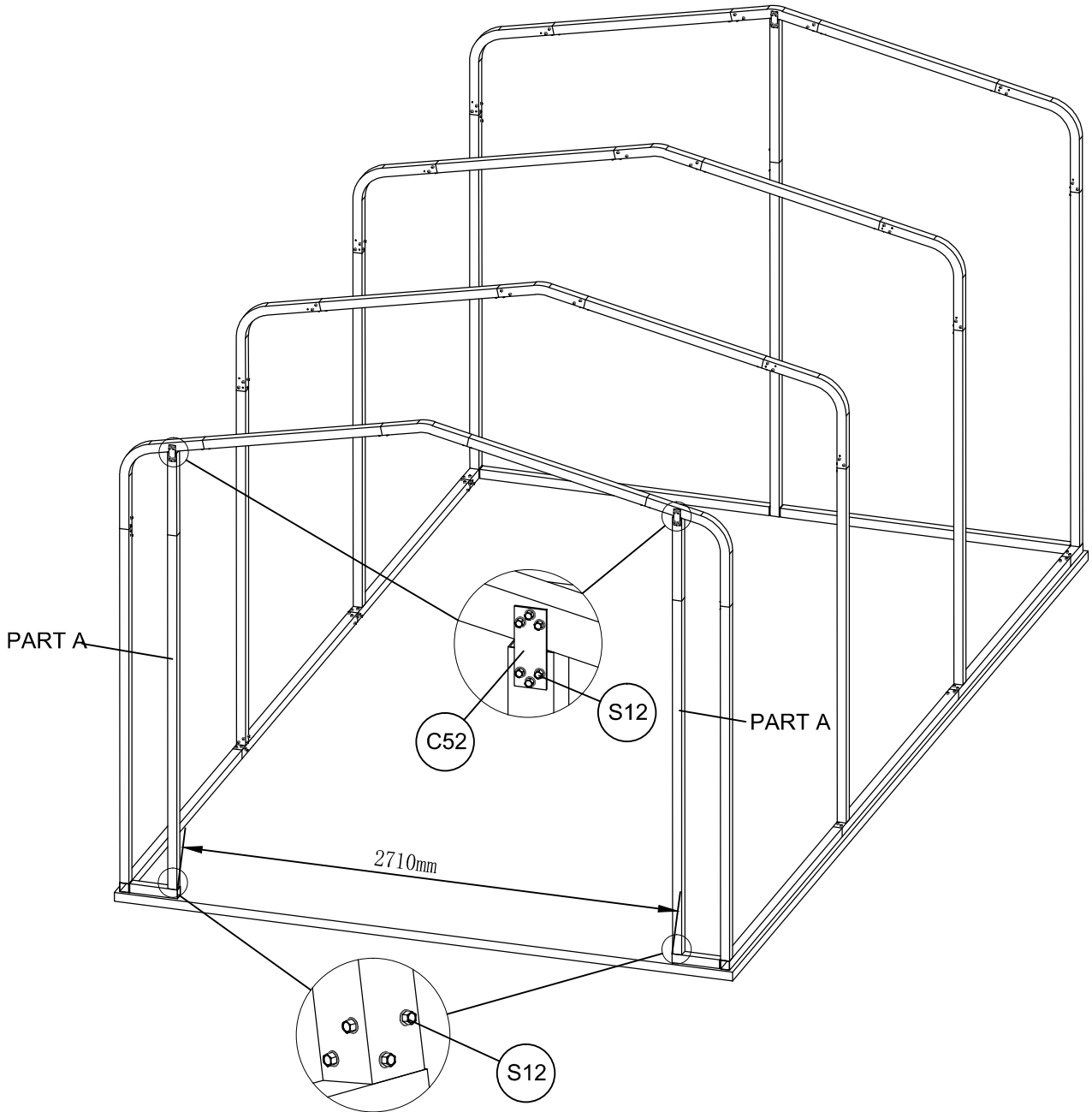

FRAME ASSEMBLY

	C52	2		S12	20
---	-----	---	---	-----	----







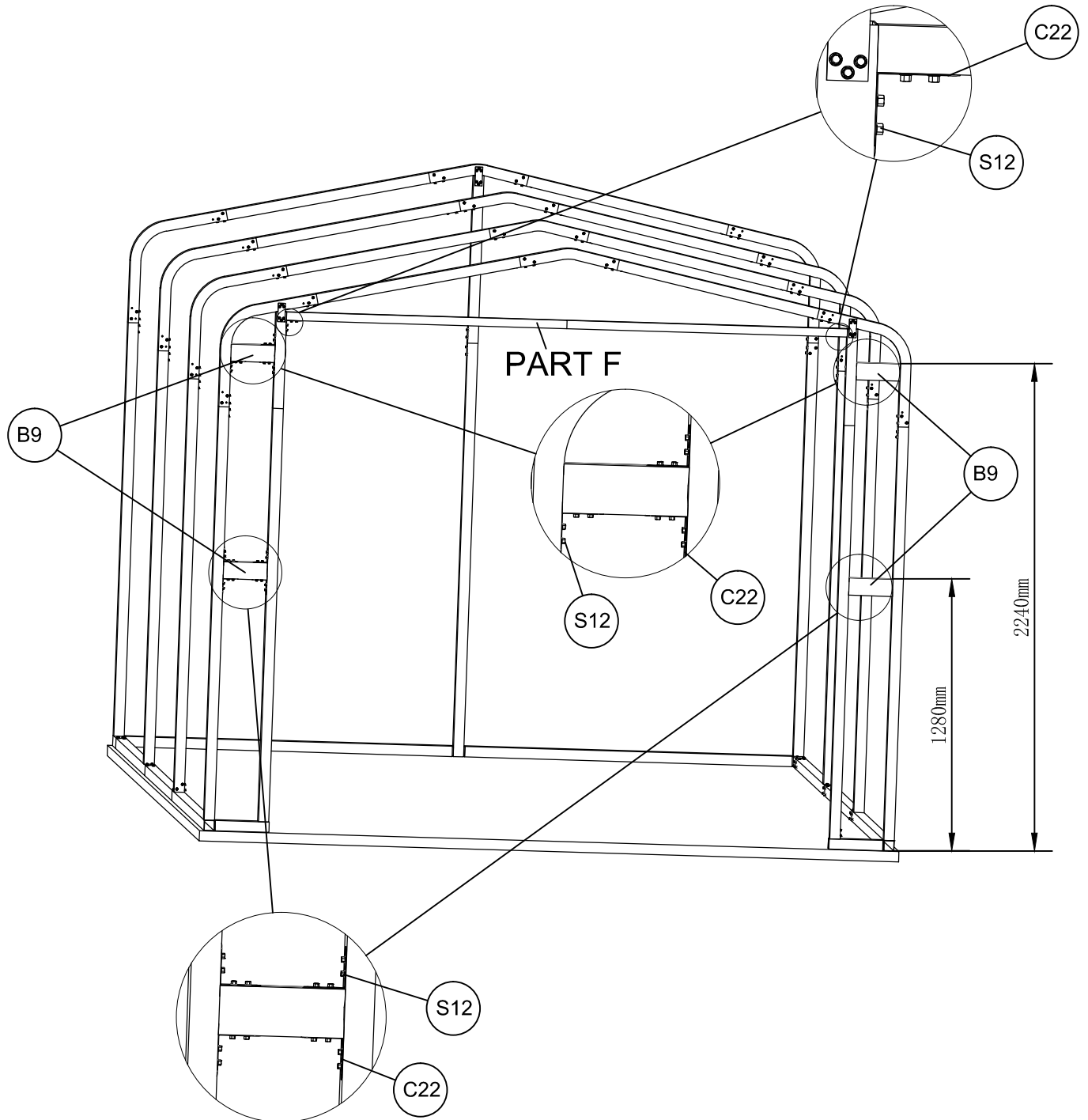



FRAME ASSEMBLY

	B9	4		C22	16		S12	64
---	----	---	---	-----	----	---	-----	----



FRAME ASSEMBLY



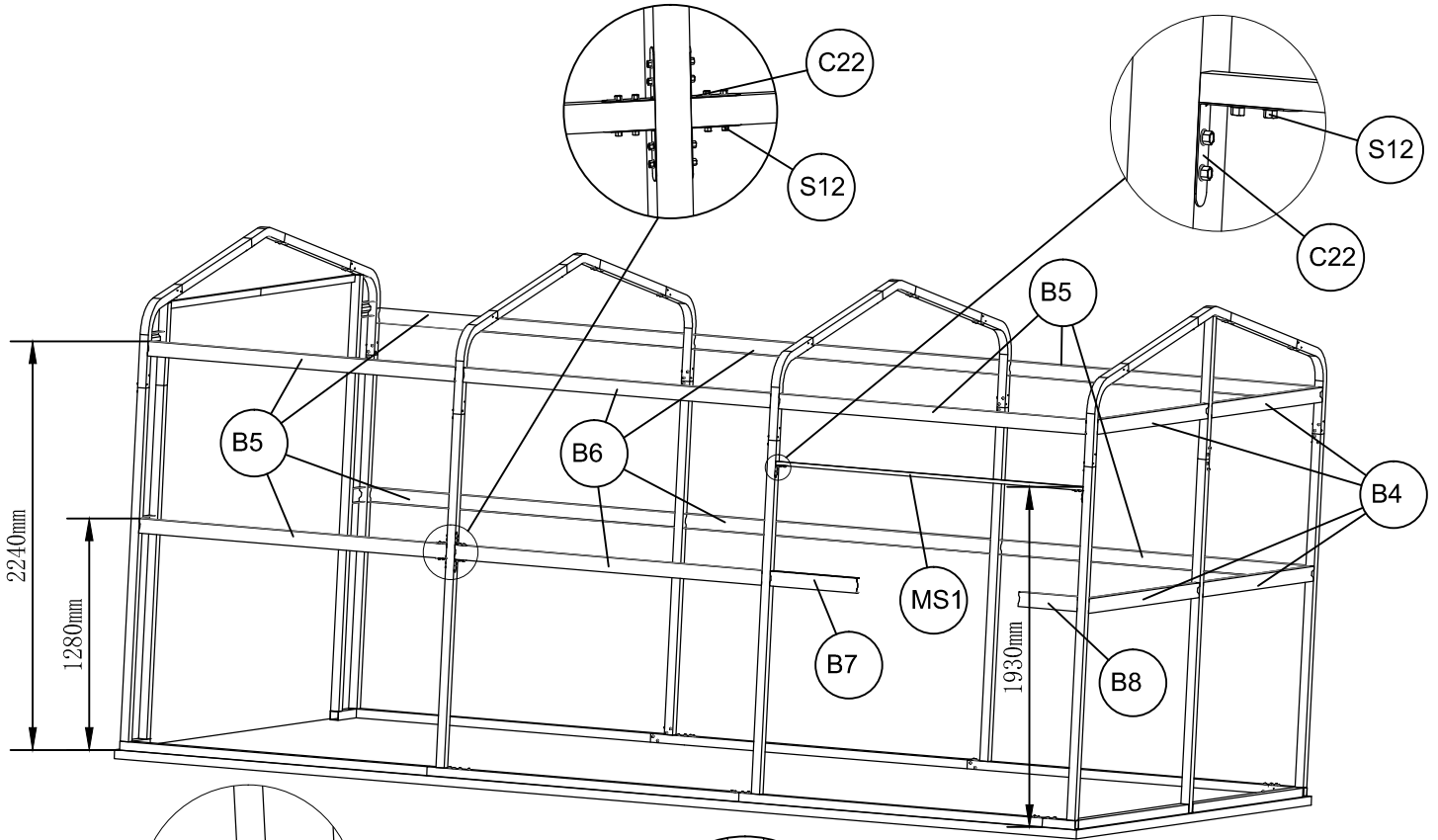

	MS1	1		B4	4		B5	7		B6	4		B7	1
	B8	1		S12	264		C22	66		L8	2			

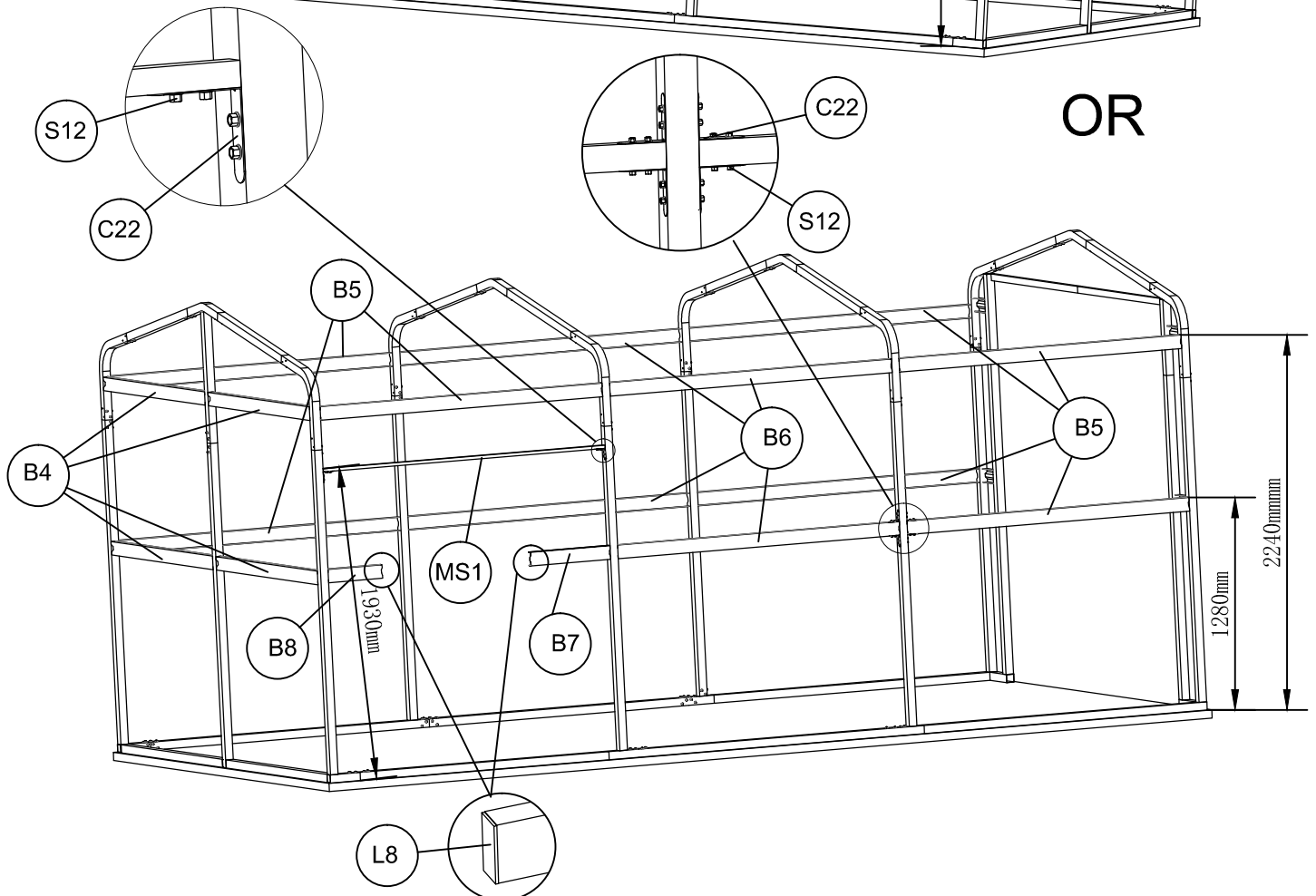

OR



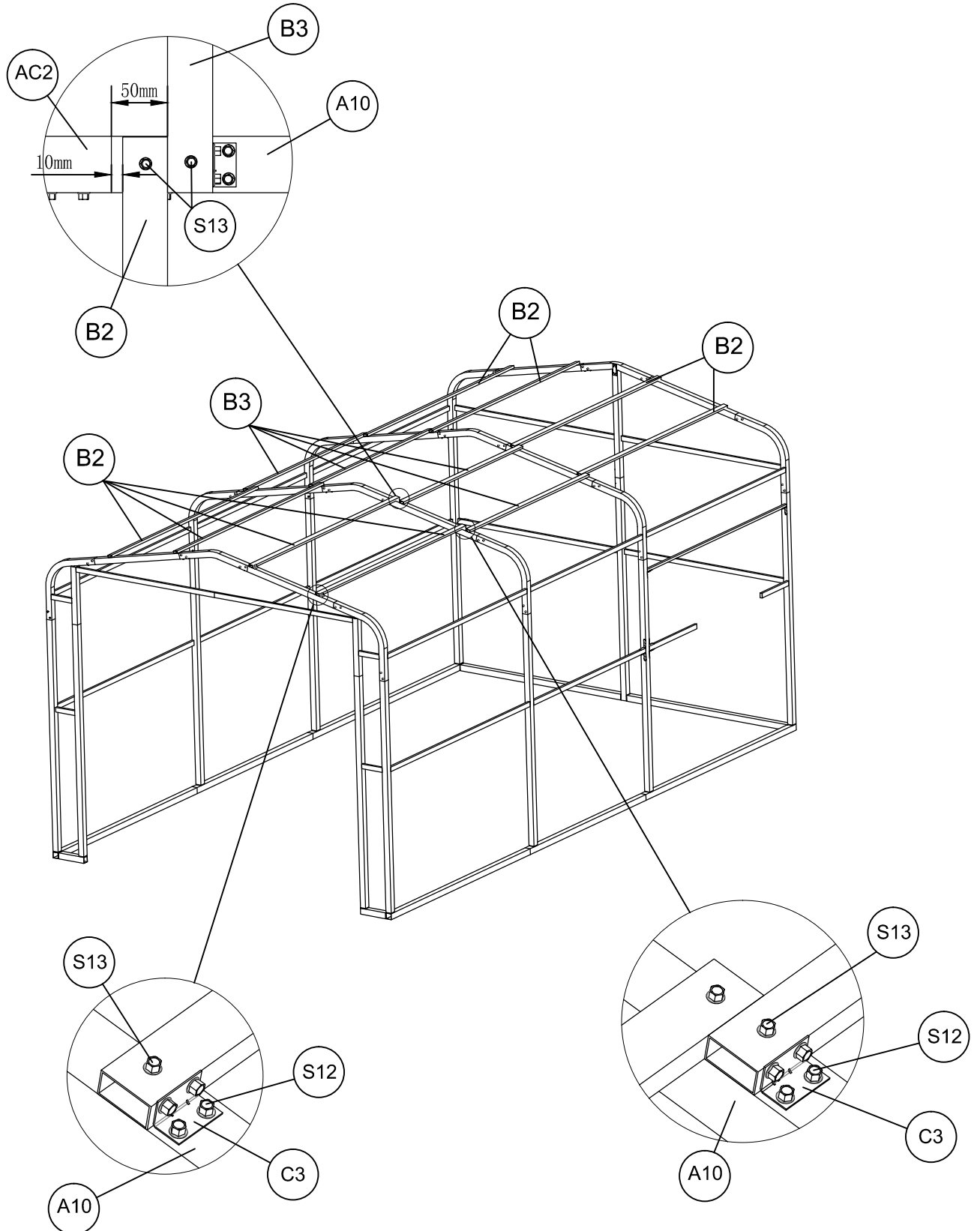

FRAME ASSEMBLY

	C3	16		B2	8		B3	4		S12	64		S13	24
---	----	----	---	----	---	---	----	---	--	-----	----	---	-----	----





PANEL ASSEMBLY

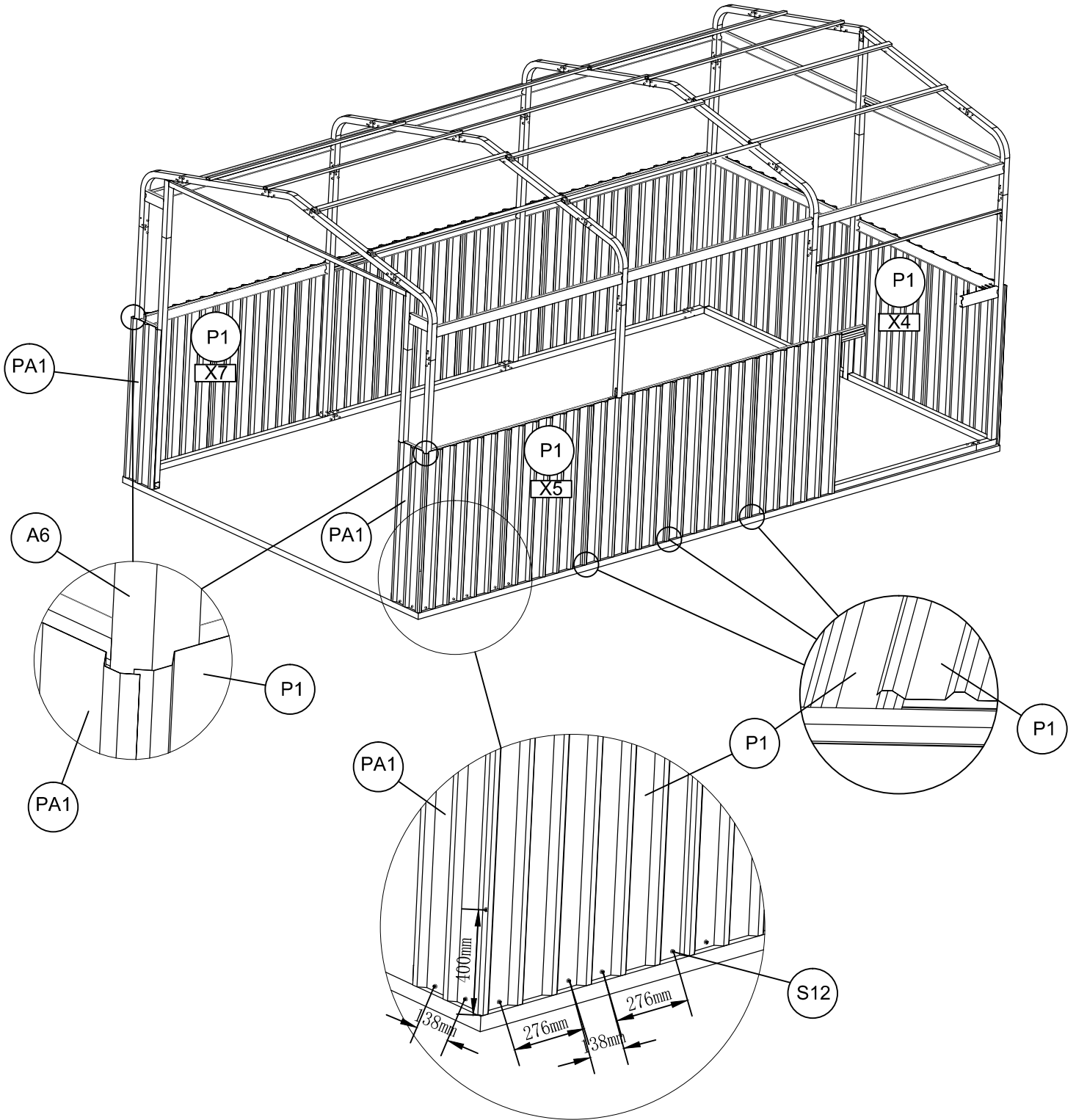





	P1	16		PA1	2		S12	71
---	----	----	---	-----	---	---	-----	----

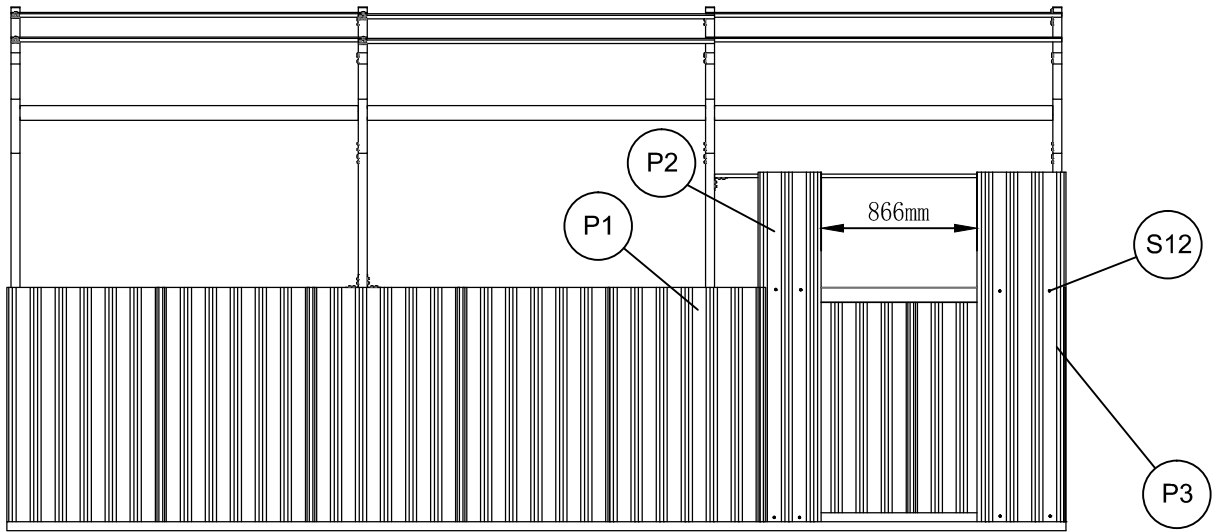

PANEL ASSEMBLY



	P2	1		P3	1		S12	8
---	----	---	---	----	---	---	-----	---

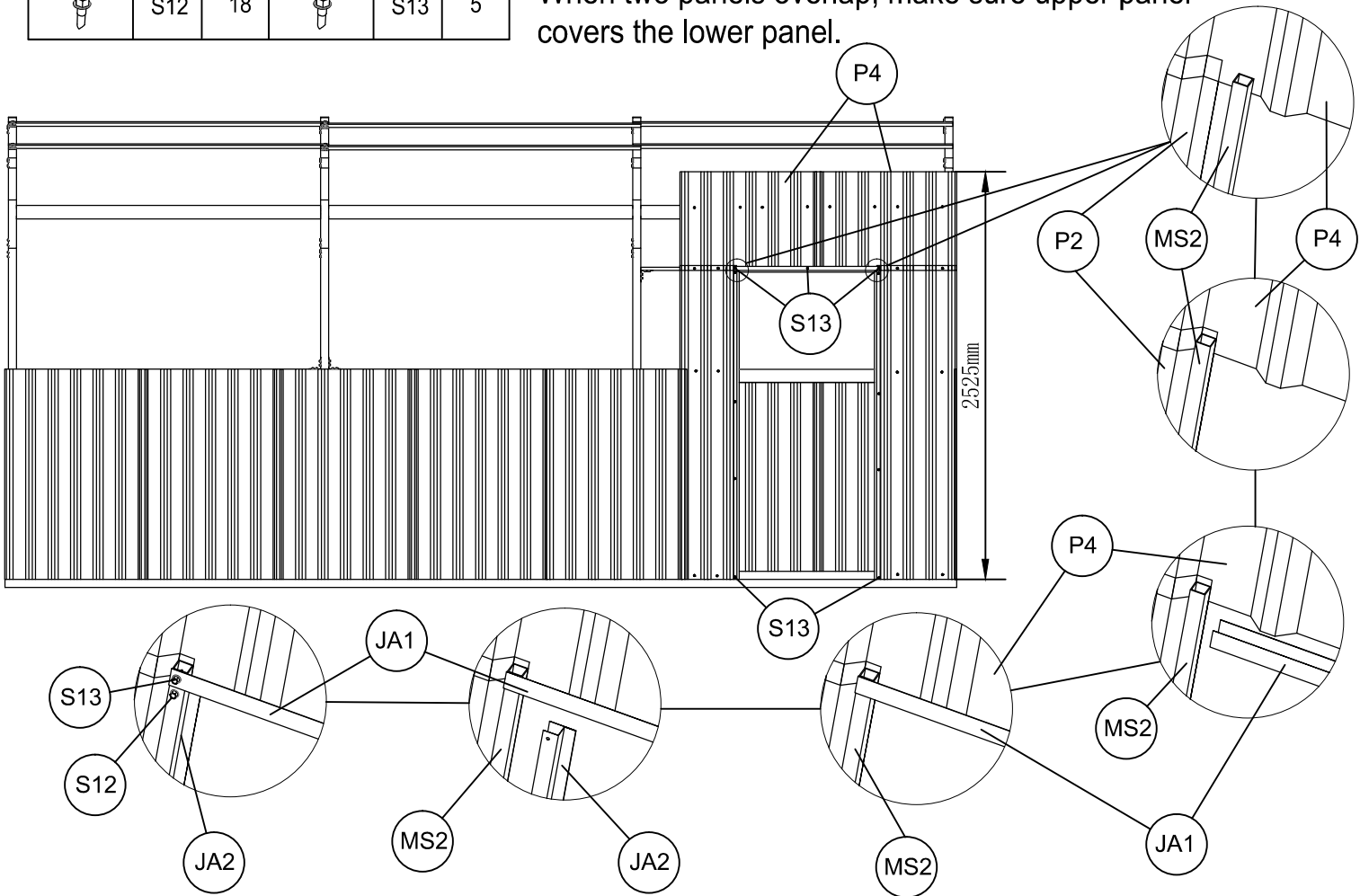

	P4	2		MS2	2		JA1	1		JA2	2
	S12	18		S13	5	When two panels overlap, make sure upper panel covers the lower panel.					





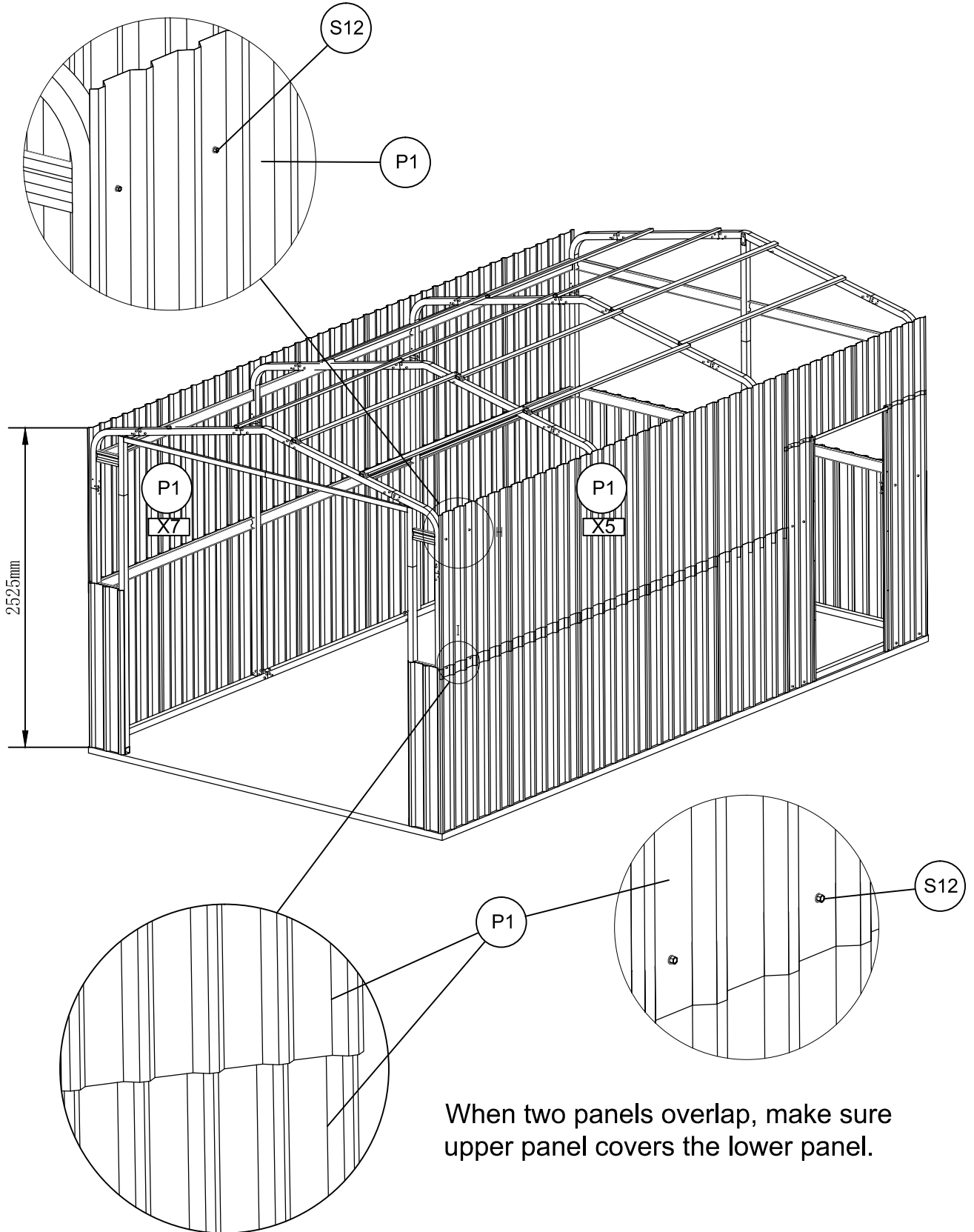

PANEL ASSEMBLY

	P1	12		S12	96
---	----	----	---	-----	----







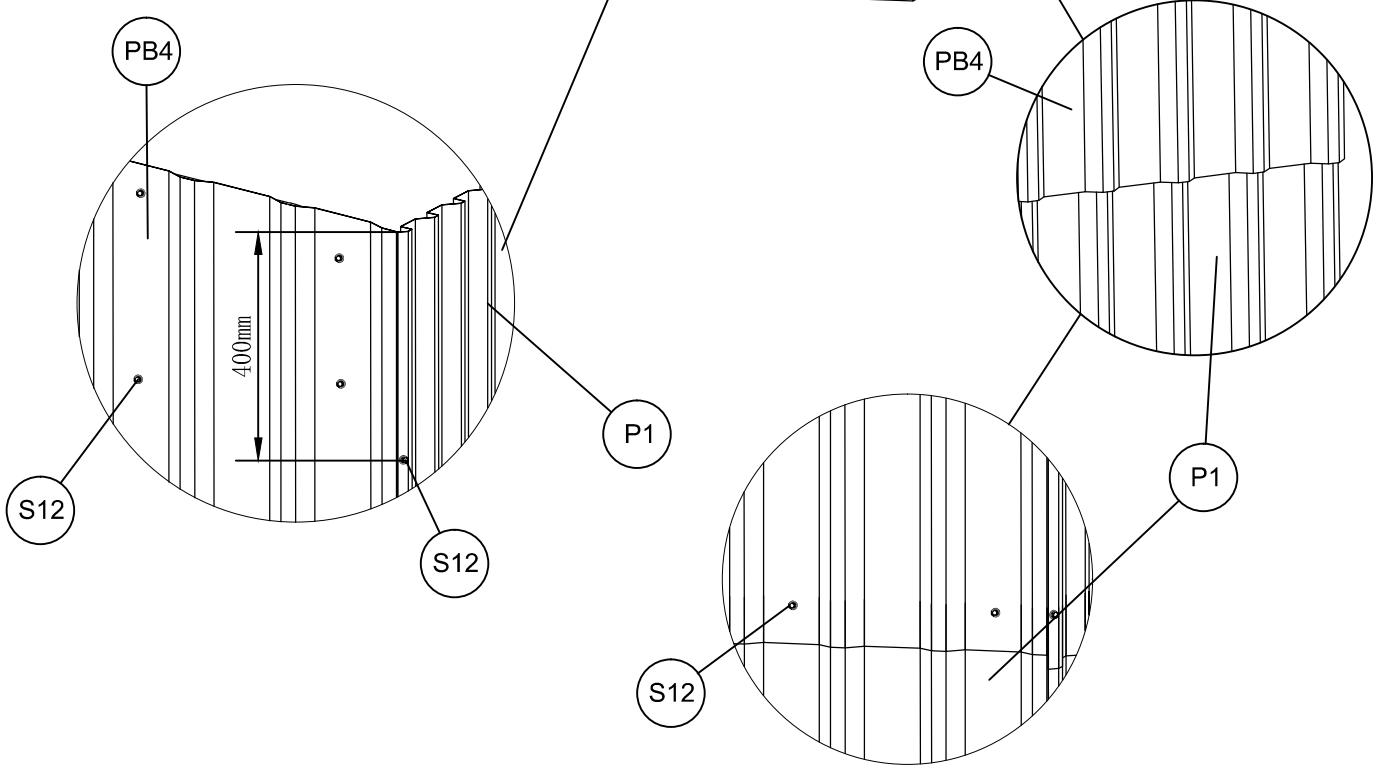
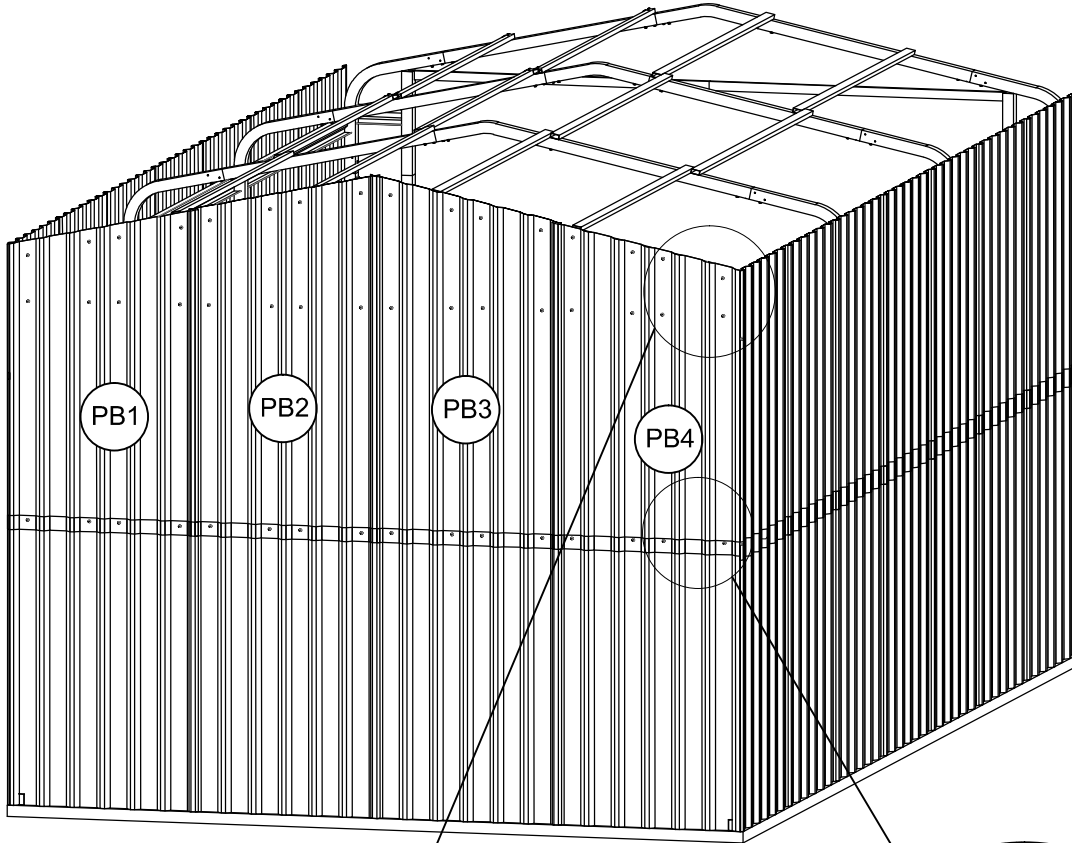

When two panels overlap, make sure upper panel covers the lower panel.

PANEL ASSEMBLY

	PB1	1		PB2	1		PB3	1		PB4	1
	S12	52									





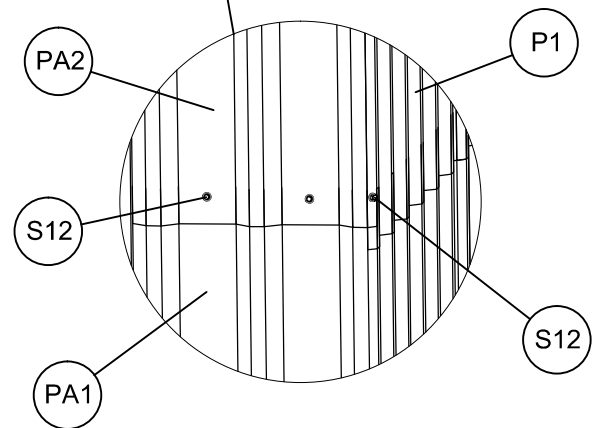
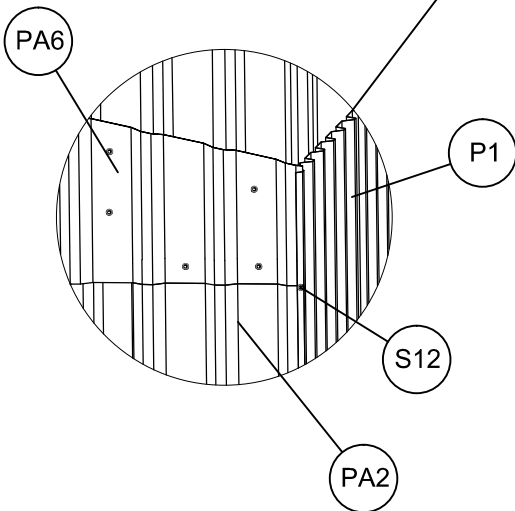
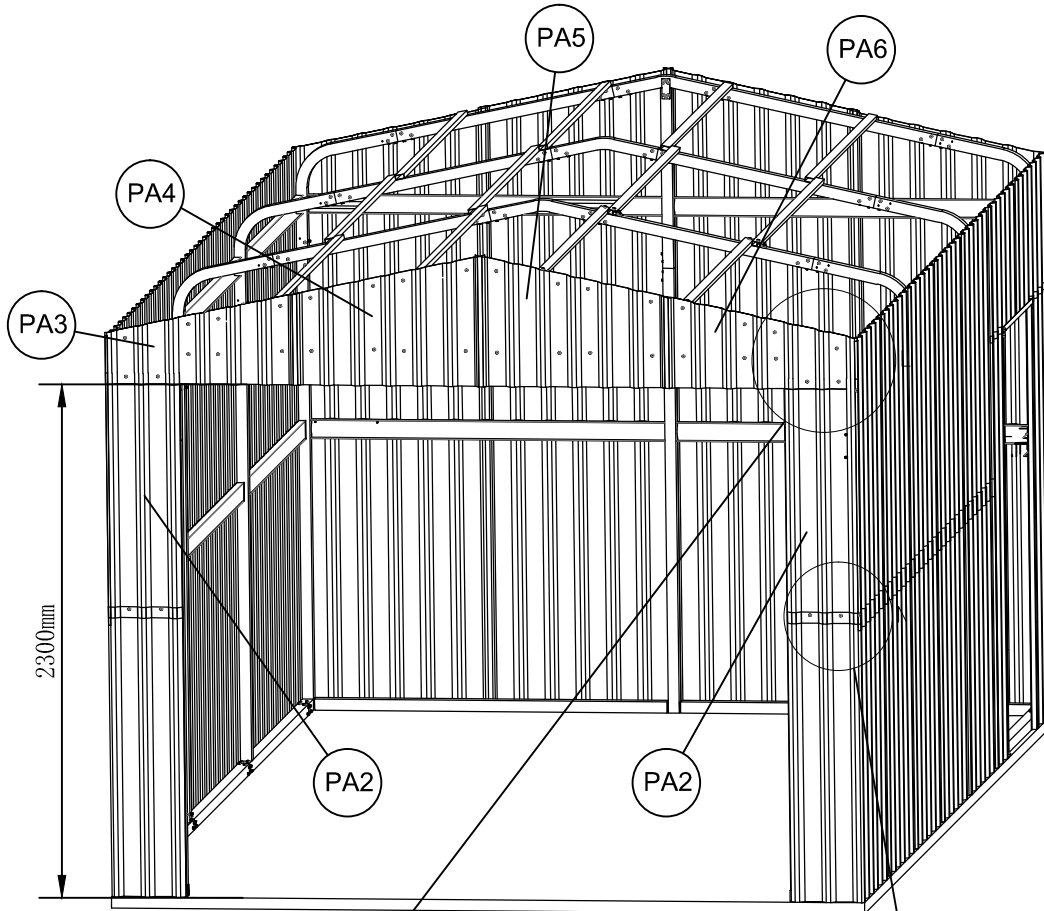

PANEL ASSEMBLY

	PA3	1		PA4	1		PA5	1		PA6	1
	S12	40		L3	4		PA2	2			





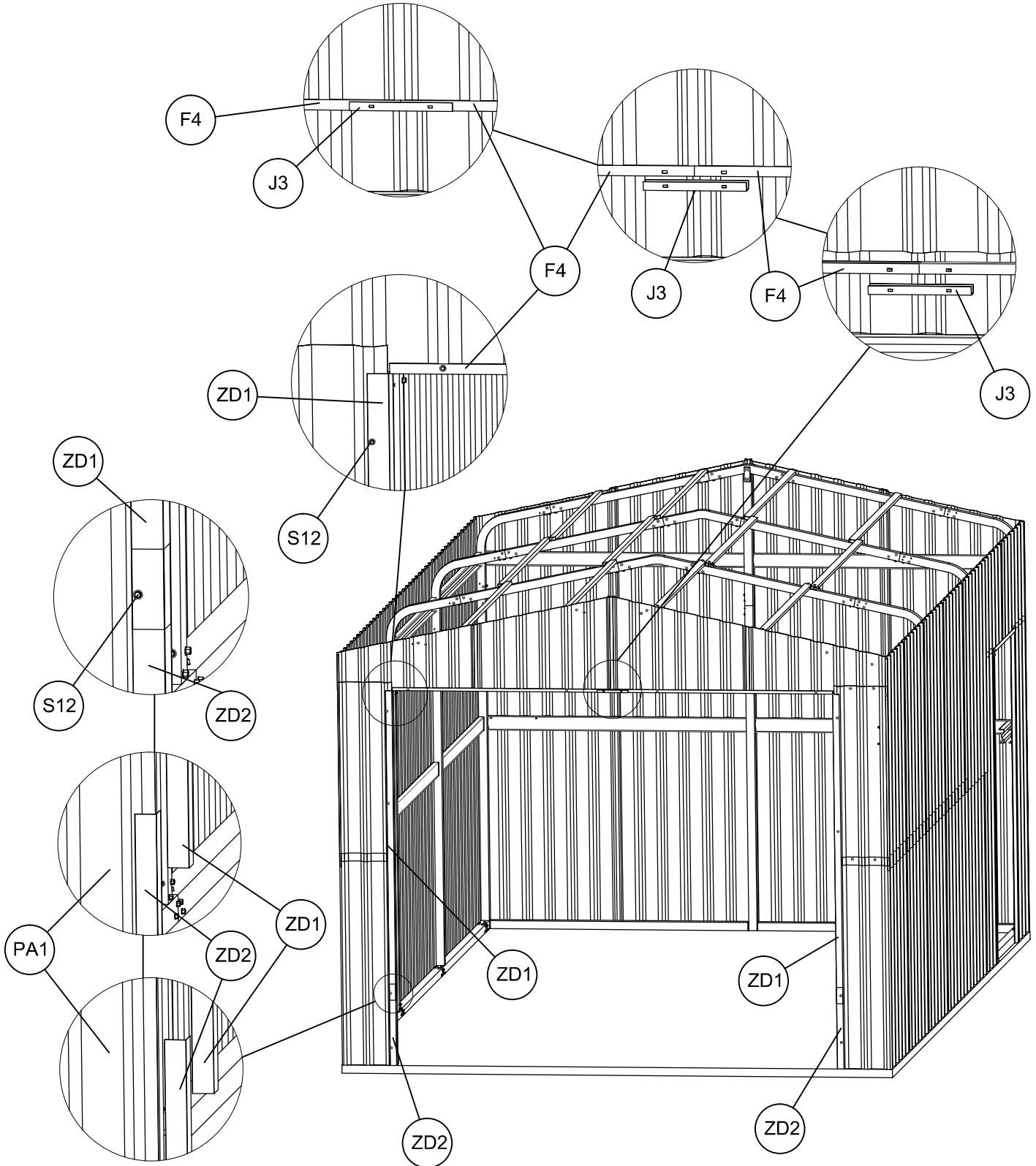

PANEL ASSEMBLY

	F4	2		ZD1	2		ZD2	2		J3	1
	S12	12									



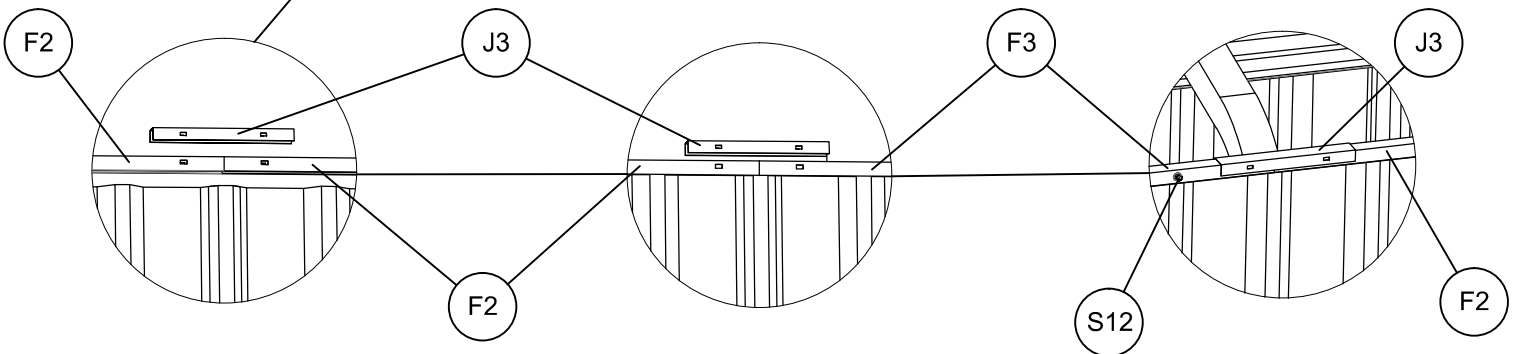
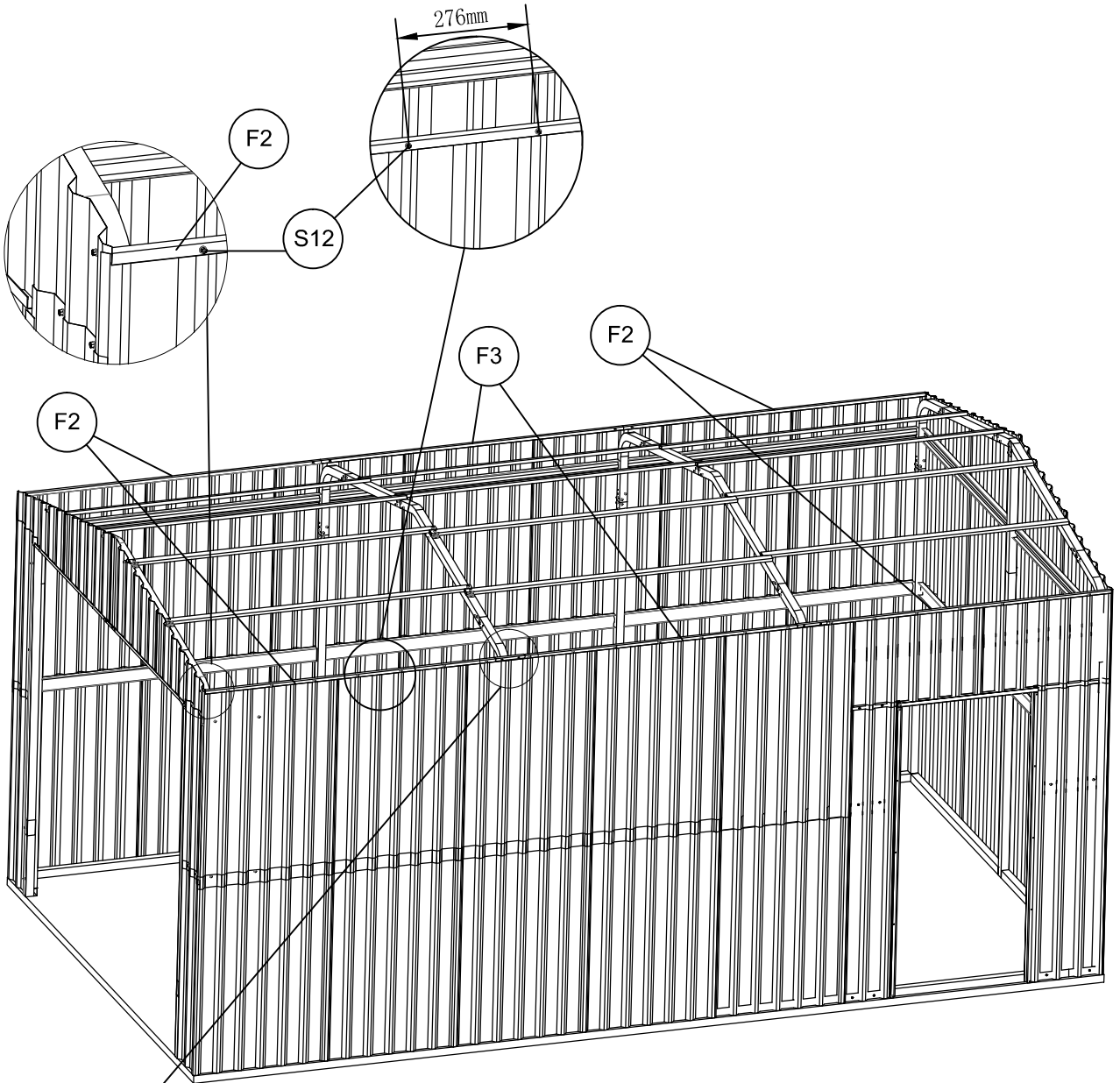

PANEL ASSEMBLY

	F2	4		F3	2		J3	4		S12	42
---	----	---	---	----	---	---	----	---	---	-----	----





PANEL ASSEMBLY

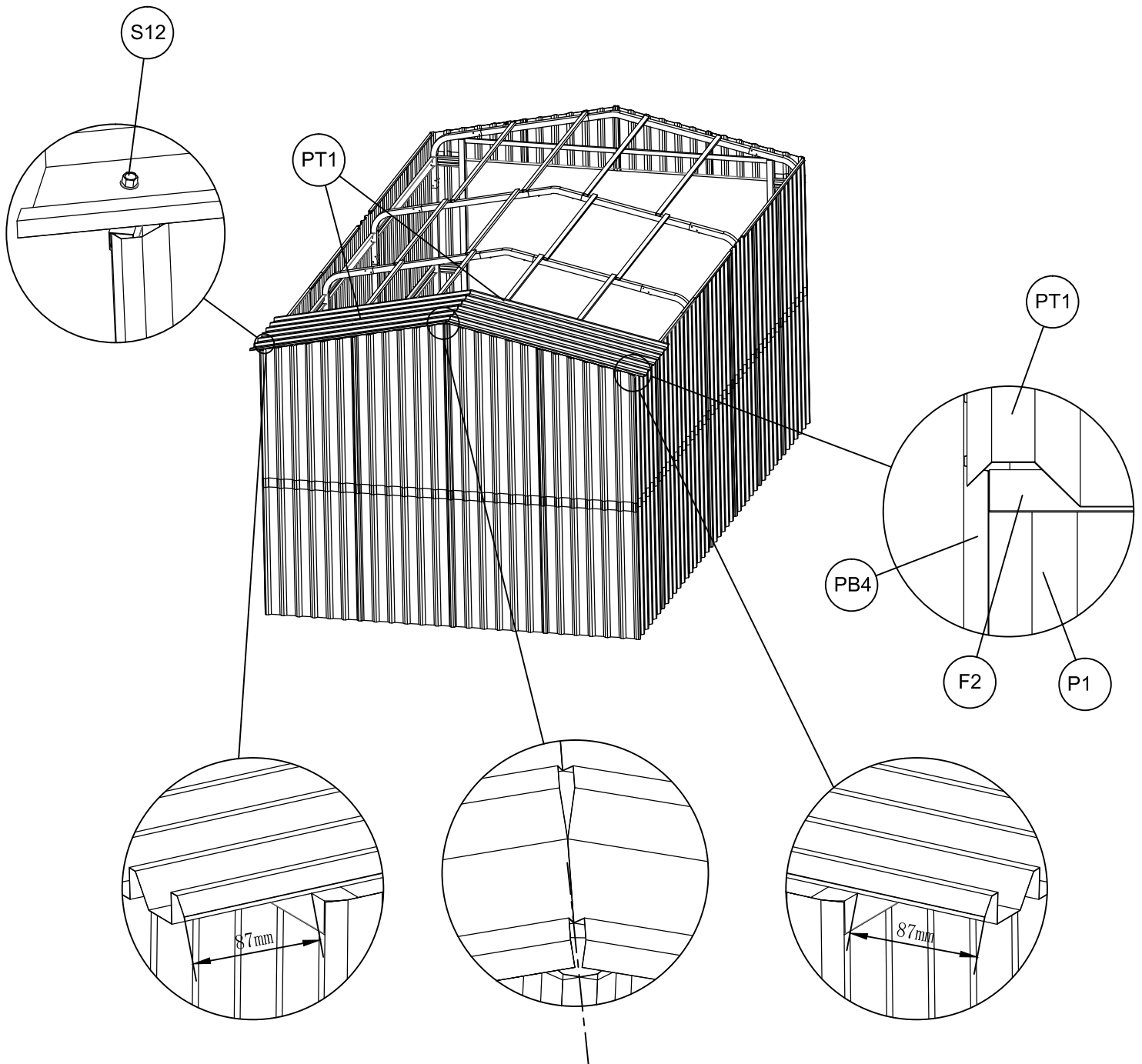



	PT1	2		S12	24
---	-----	---	---	-----	----

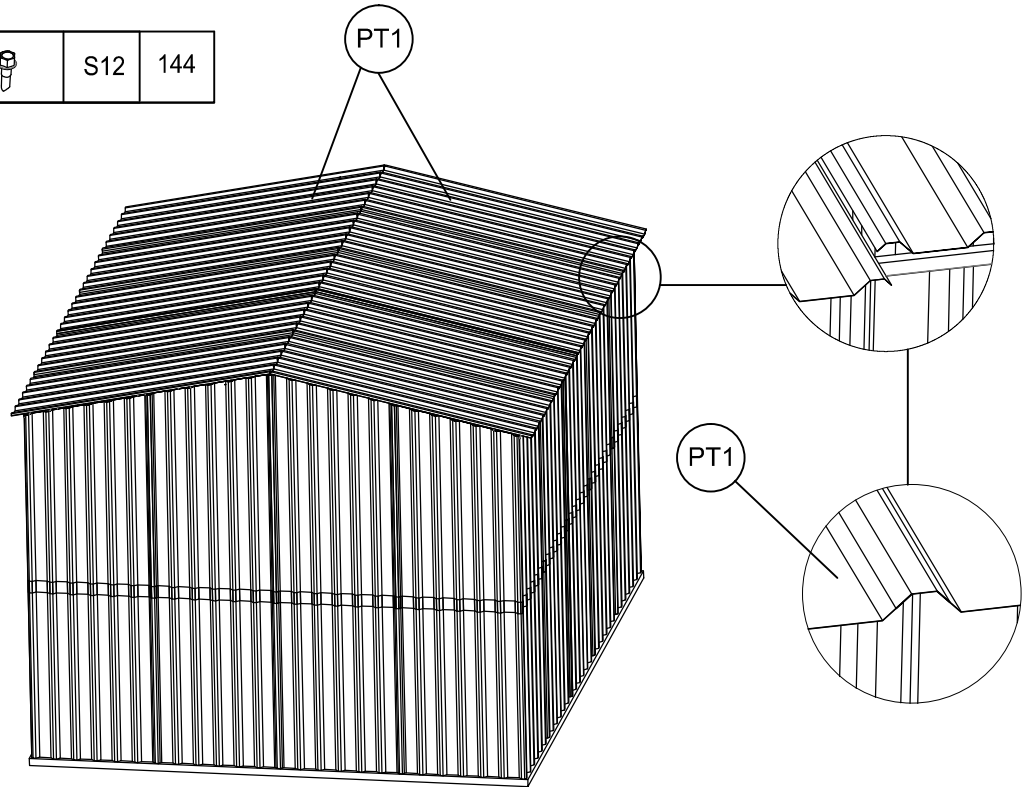

PANEL ASSEMBLY





	PT1	12		S12	144
---	-----	----	---	-----	-----

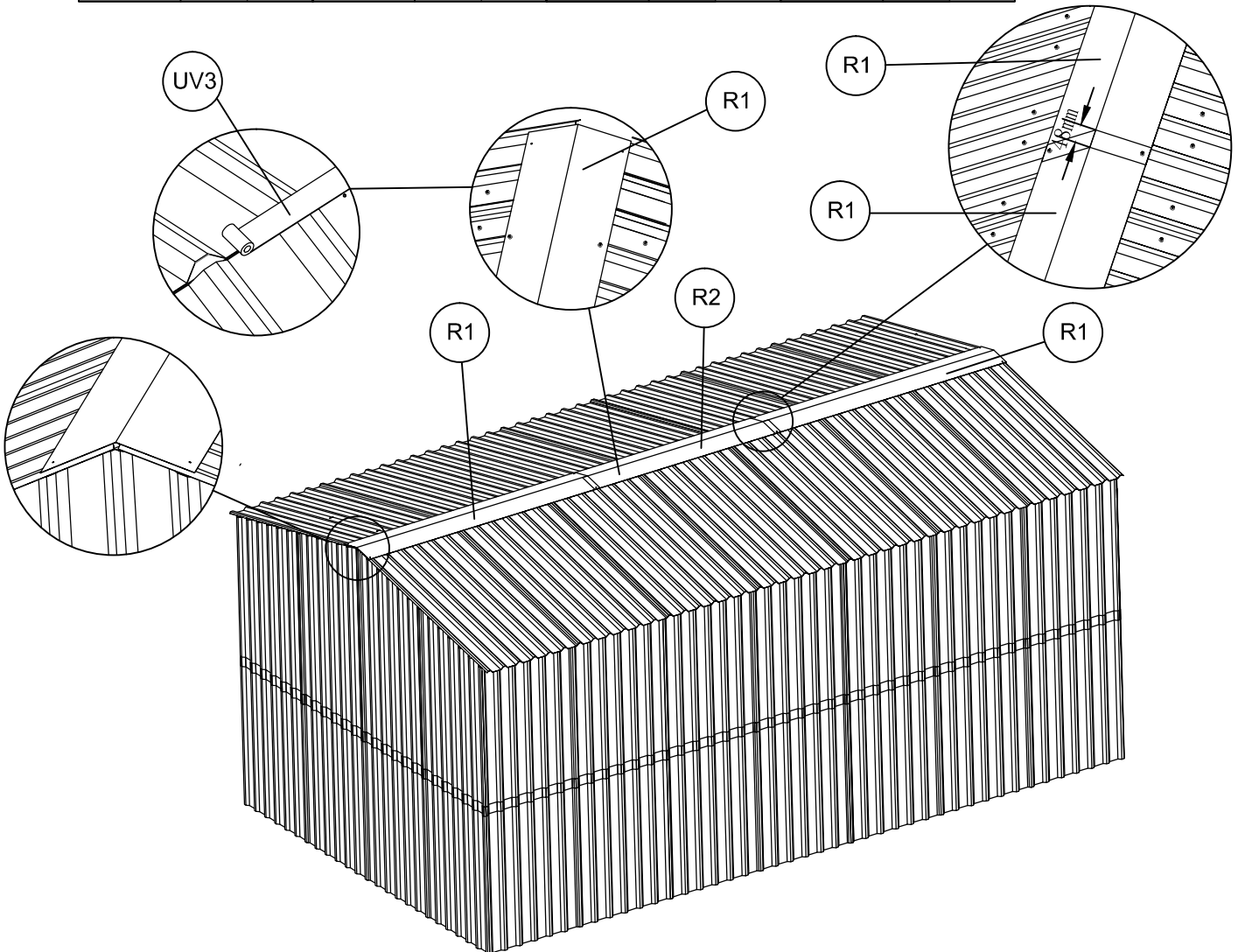

	R1	2		R2	1		UV3		S12	10
---	----	---	---	----	---	---	-----	--	-----	----





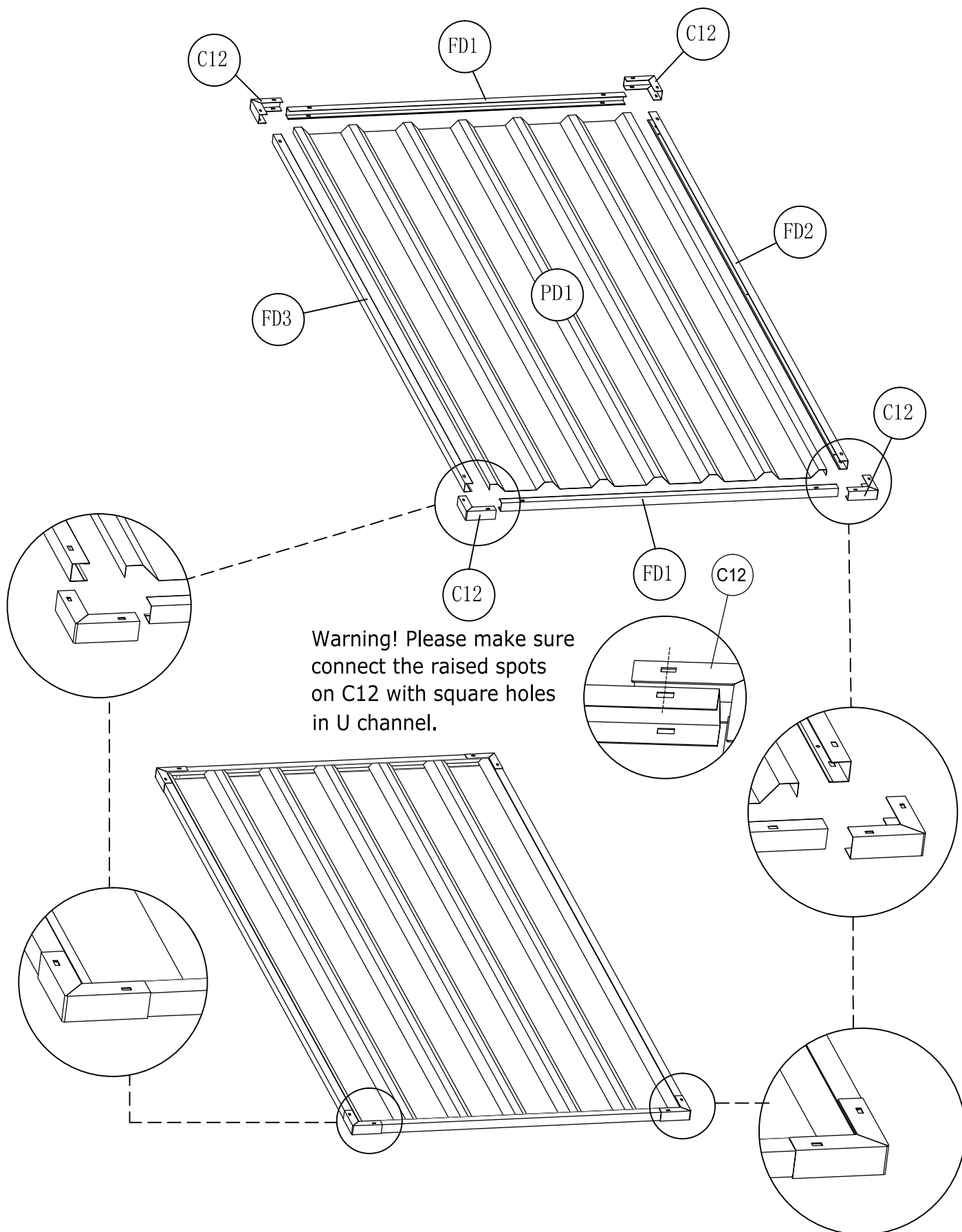

DOOR ASSEMBLY

	PD1	1		FD1	2		FD3	1
	C12	4		FD2	1			





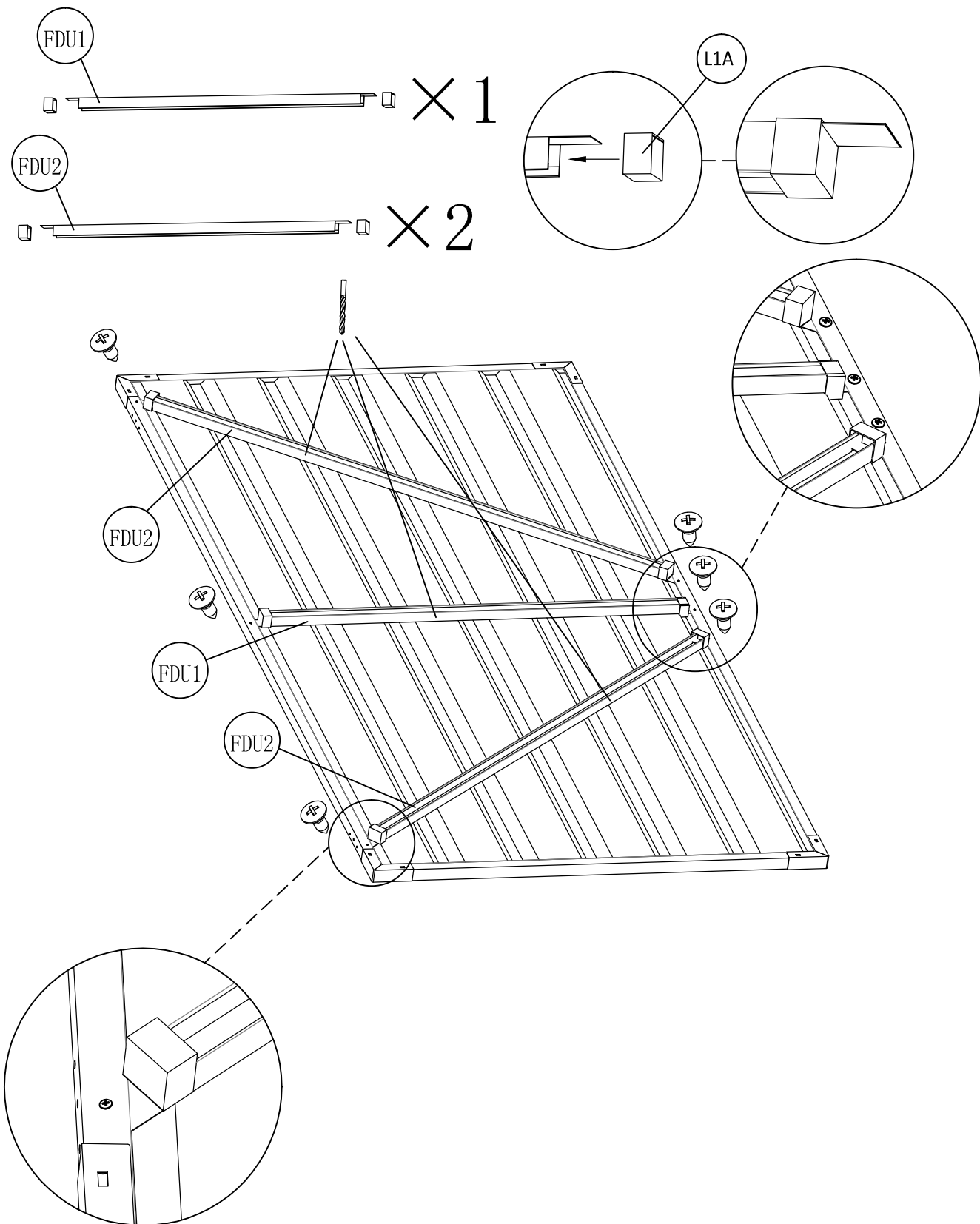

DOOR ASSEMBLY

	FDU1	1		FDU2	2
	S3	6		L1A	6

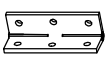

DOOR ASSEMBLY

	SH1	2		S3	18
	S7	6		L3	18

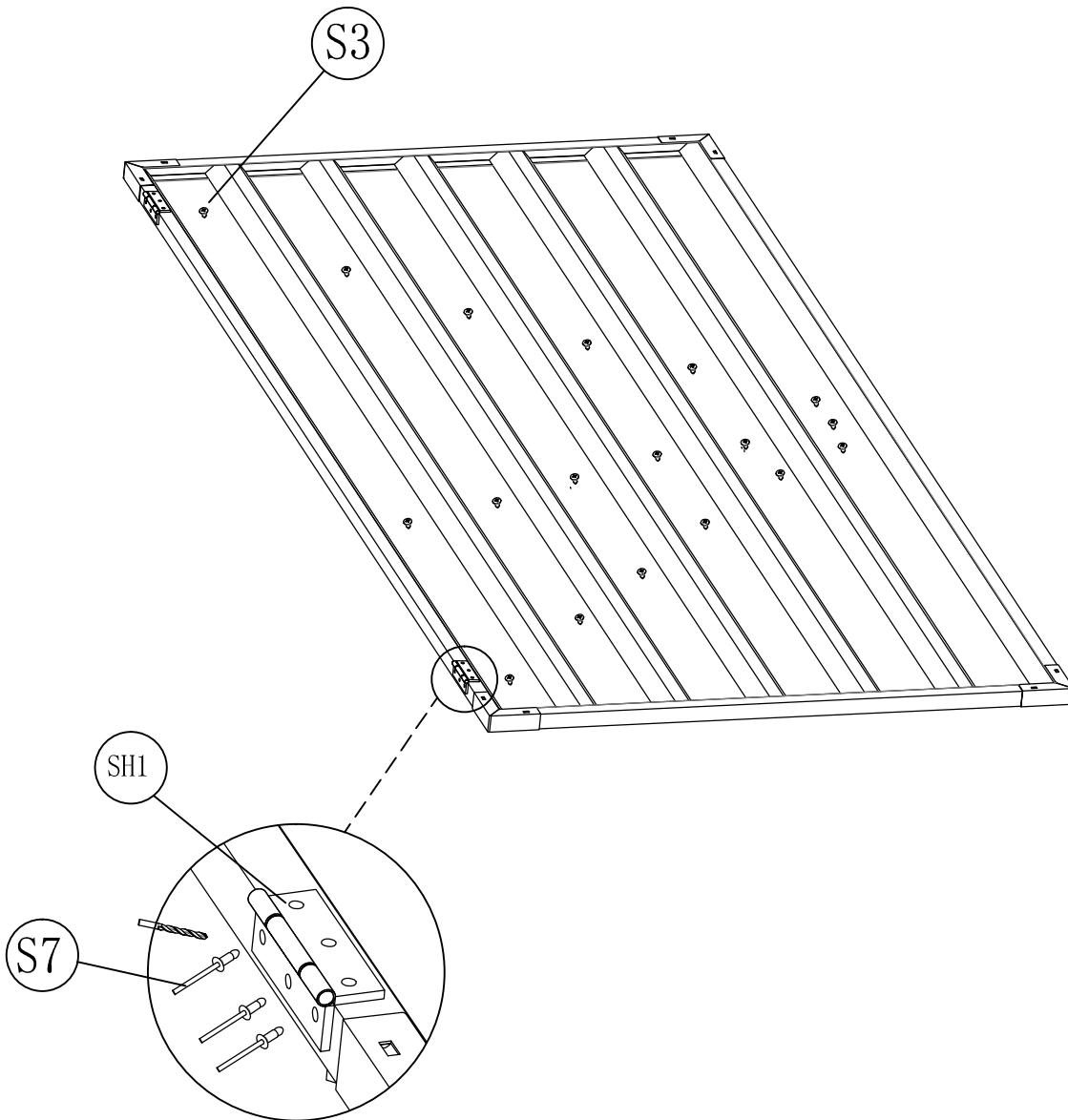

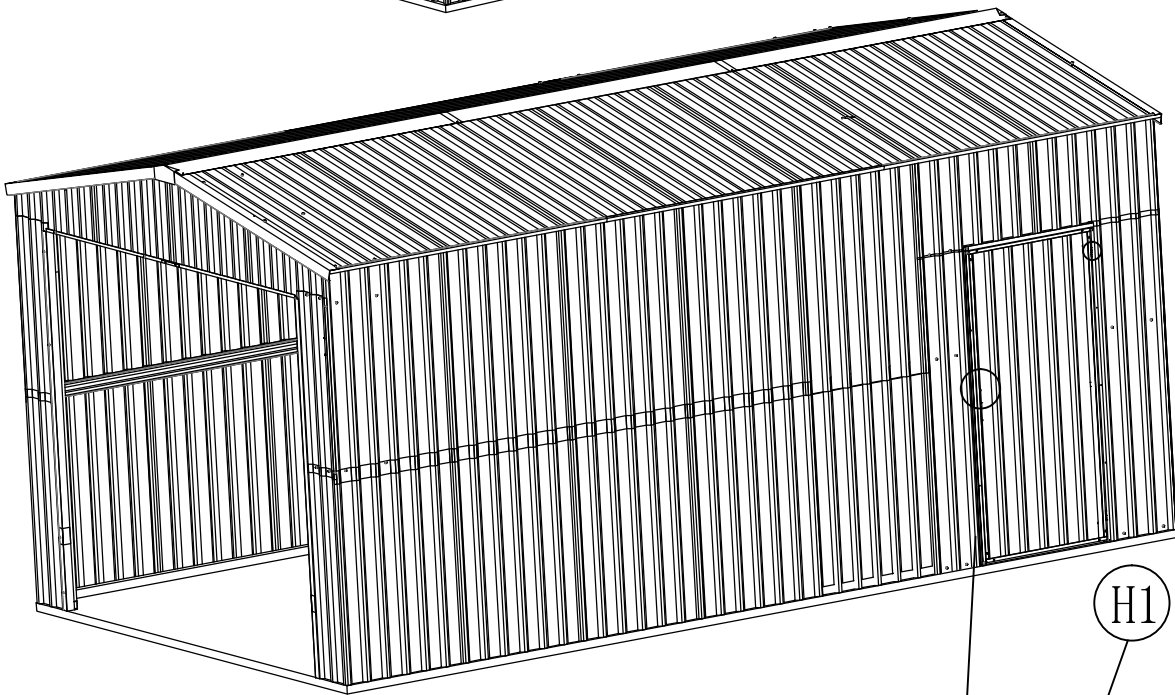
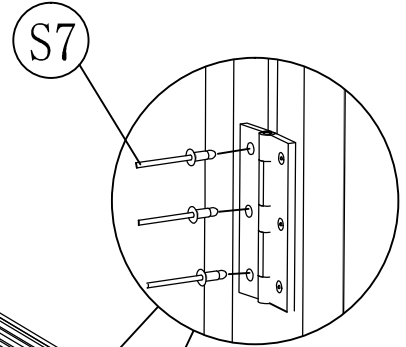
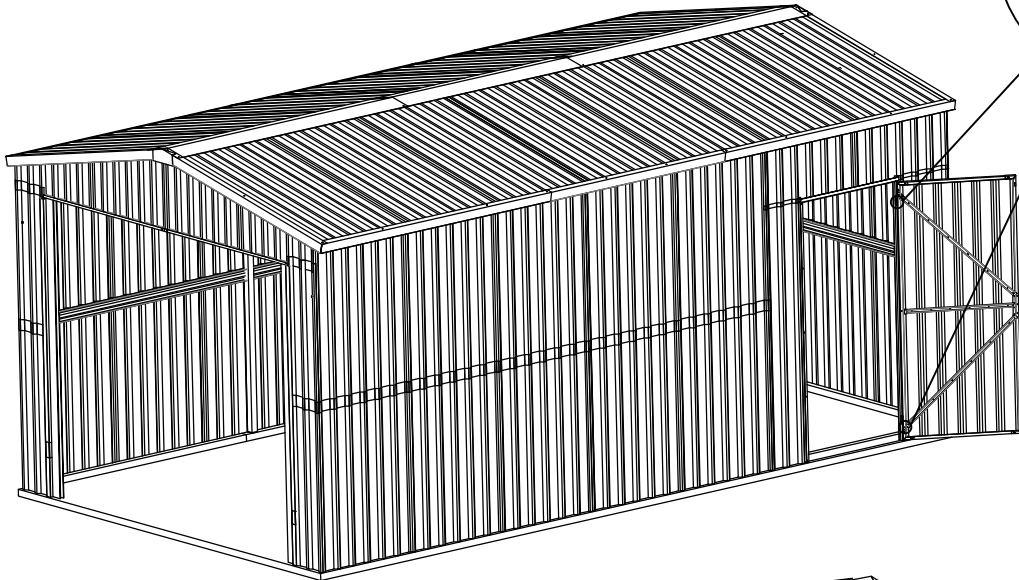

SHED ASSEMBLY

	S7	6
---	----	---



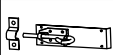

H1

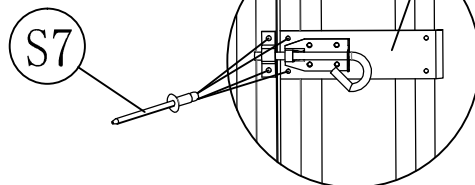
	H1	1
	S7	6





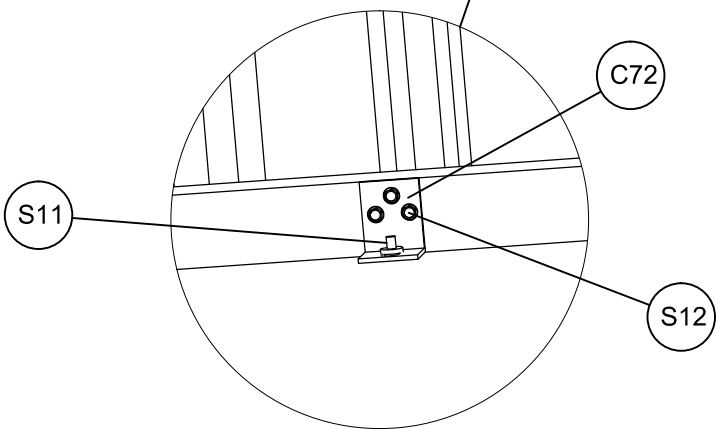
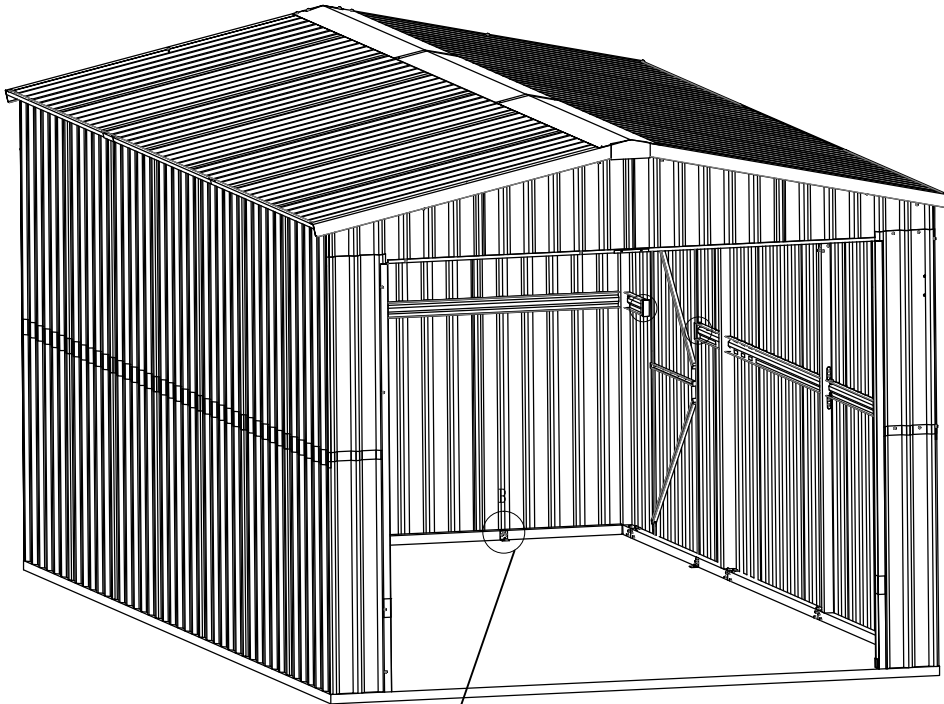

SHED ASSEMBLY

	C72	10		S12	30
	S11	10			

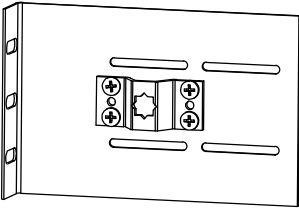
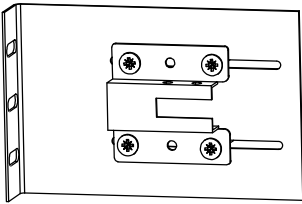
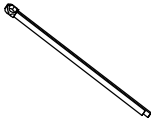
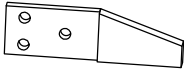
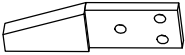

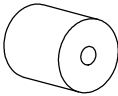
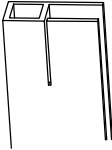
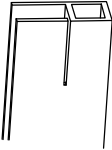
ASSEMBLY OF THE DOOR MAY REQUIRE THE FOLLOWING PARTS

				
A	S	C	M	
				
N	O	P	GR1	GR2
				
S12	S13			

SHED ASSEMBLY - ROLL UP DOOR

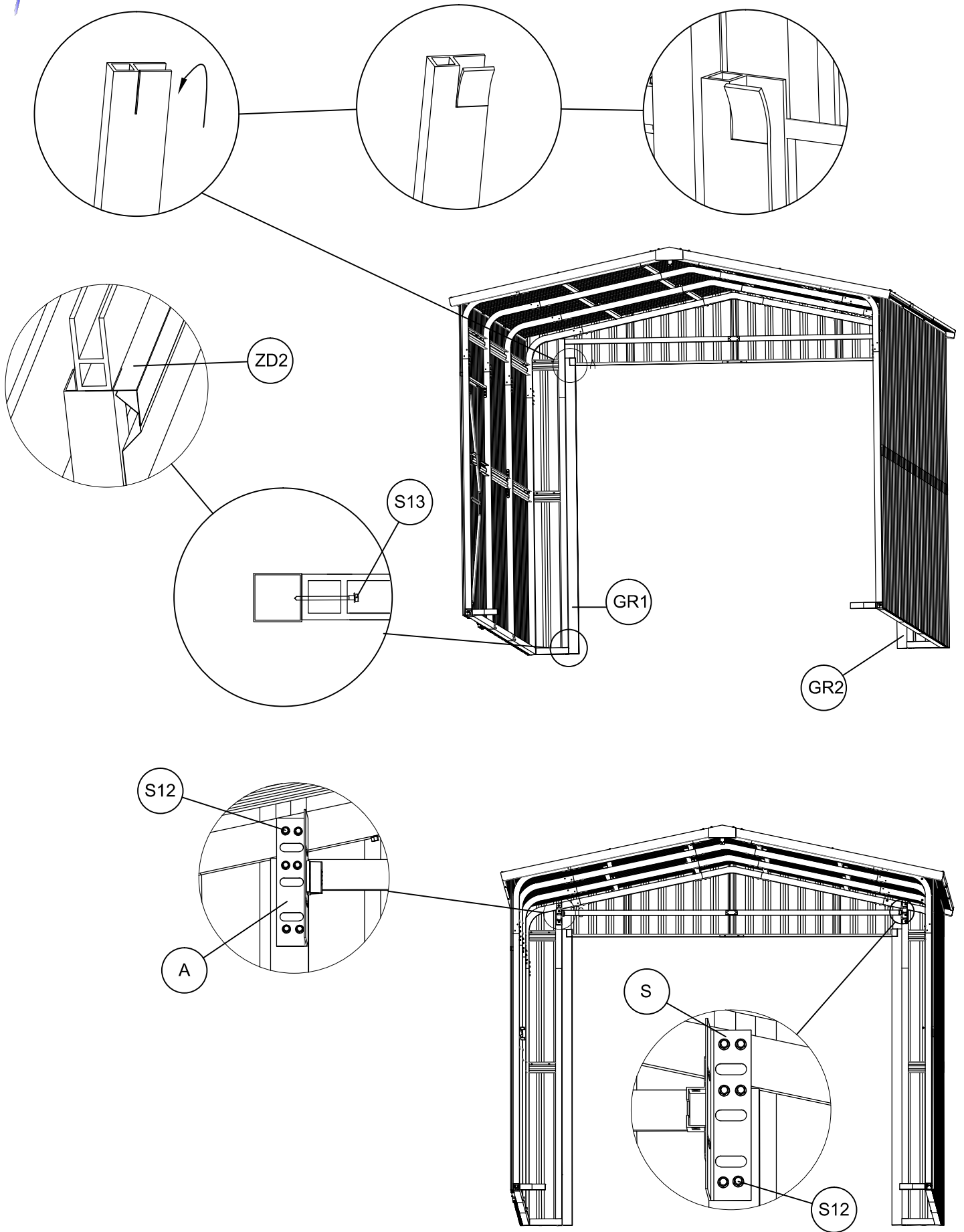

SHED ASSEMBLY - ROLL UP DOOR

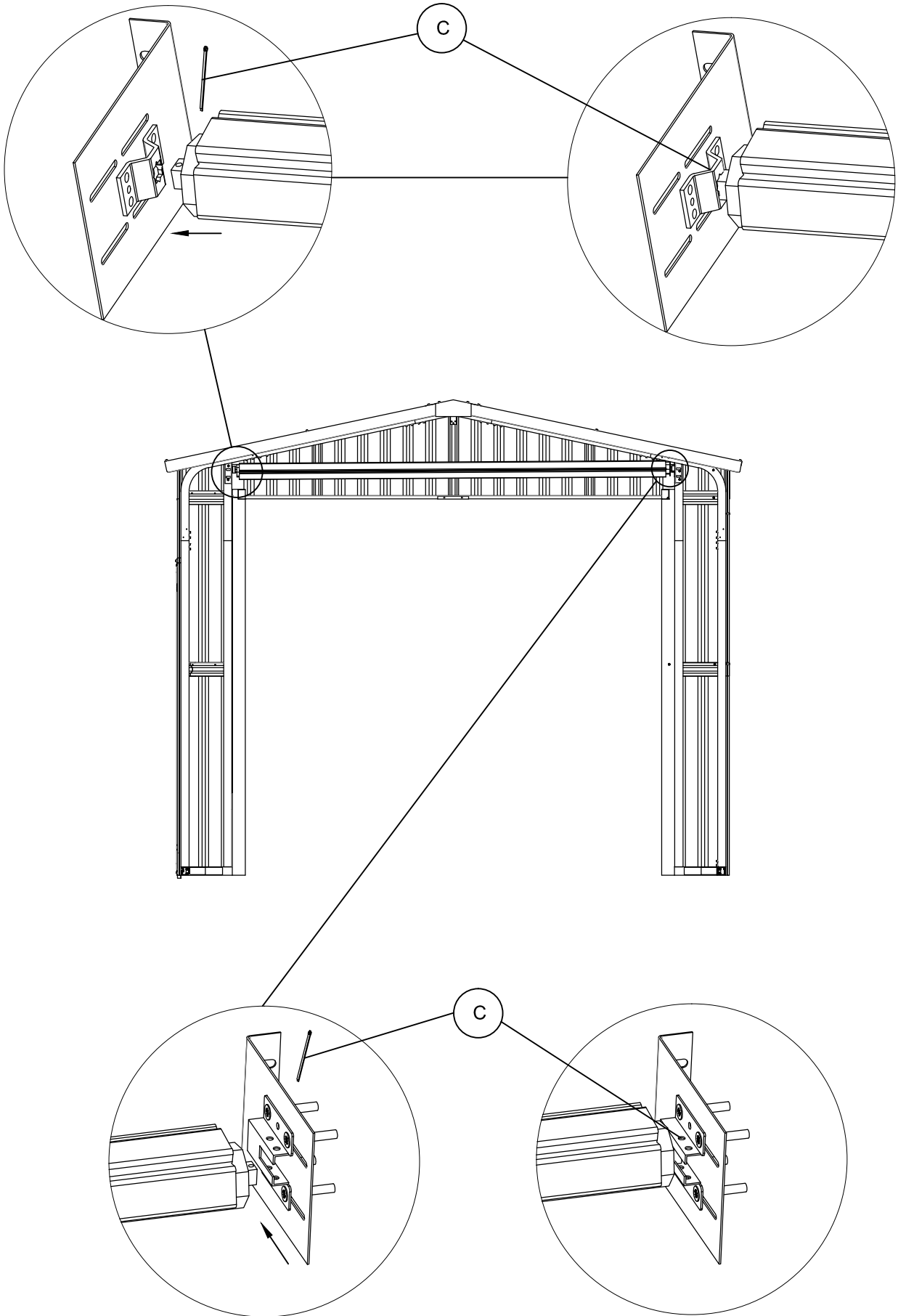

SHED ASSEMBLY - ROLL UP DOOR

Bind the roller door before rotating.

Idle about two circles in the direction of the arrow, if the tightness is moderate, insert the roller door into the guide rail. Pull the door edge softly with hands, infer to the top of the door, and see if the strength is proper. If you think the strength is improper, secede from the guide rail, then increase or decrease torque again. Do as the above approach until the roller door pushes and pulls smoothly.

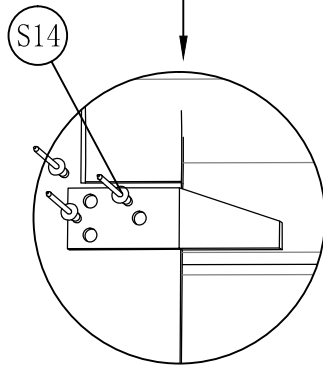
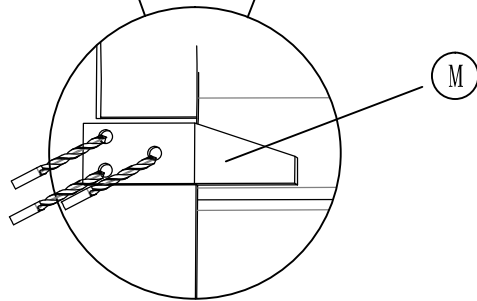
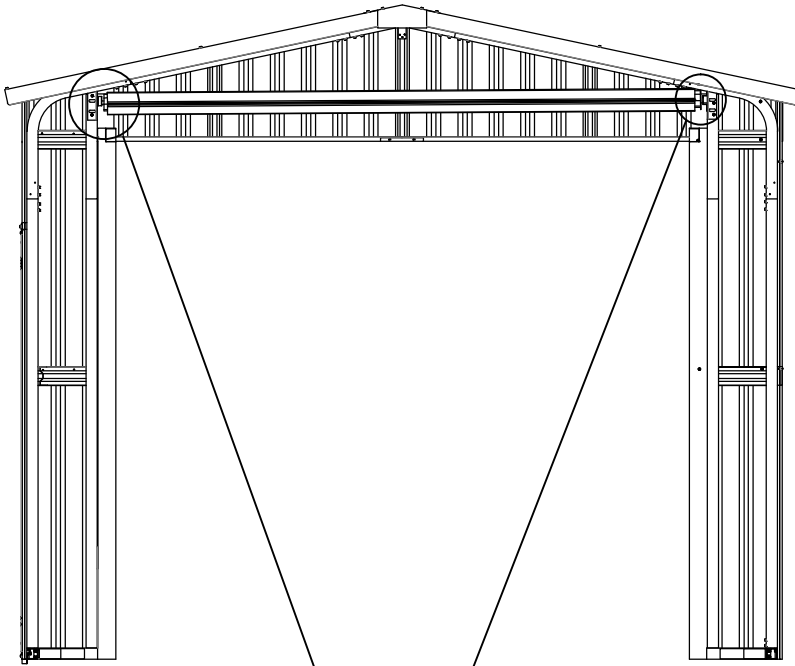

INCREASE THE TORQUE

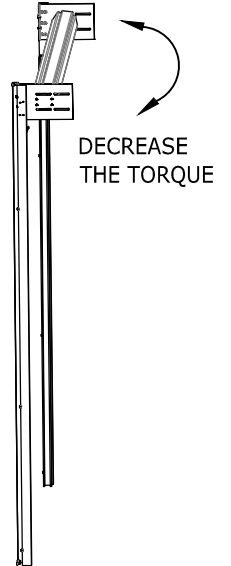

SHED ASSEMBLY - ROLL UP DOOR

