

Safety

Warning:

For safety, these safety measures must be followed at all times. Failure to do so may result in serious injury or damage to the machine.

1. Basic precautions

1.1 Safety rules

Only trained or designated personnel should operate and maintain the machine.

When performing operating and maintenance work on the machine, be sure to follow all safety rules, precautions and instructions for use.

Do not operate the machine if you feel unwell, have taken drugs that may cause drowsiness, or have drunk alcohol. Operating under these conditions may impair your judgment and result in an accident.

When working with another operator, or with a workplace traffic controller, be sure all hand signals used are understood by all personnel.

Always follow all safety regulations.

1.2 Safety devices

Be sure to ensure that all guards and covers are in the correct position. If there is any damage, ask someone to repair it.

Properly use safety devices such as safety locking levers  and seat belts.

Never remove any safety devices, always keep them in good working order.

Safety locking lever for parking the machine

Seat Belts See Seat Belt Use

Improper use of safety devices may cause serious personal injury.

1.3 Be sure to lock the driver's seat when leaving it

When standing up from the driver's seat, be sure to place the safety lock lever

firmly in the LOCK position. If the joysticks are not locked and they are accidentally touched, the work equipment may suddenly move causing serious injury or damage.

When leaving the machine, the working device should be completely lowered to the ground and the safety locking lever should be placed in the LOCK position. Then shut off the engine and lock all equipment with the key. Be sure to remove the key and take it with you.

1.4 Getting on and off the machine

Never jump on or off the machine. Never get on or off a moving machine.

- When getting on and off machines, always face the machine and use handrails and ladders. Do not hold any control levers or safety lock levers.

Frequently wipe off oil and dirt from handrails and ladders to keep them clean.

If you need to grab the handrail on the door when getting on or off the machine, or walking on the track, open the door and lock it securely in the open position.

Otherwise the door may move suddenly, causing you to lose your balance and fall.

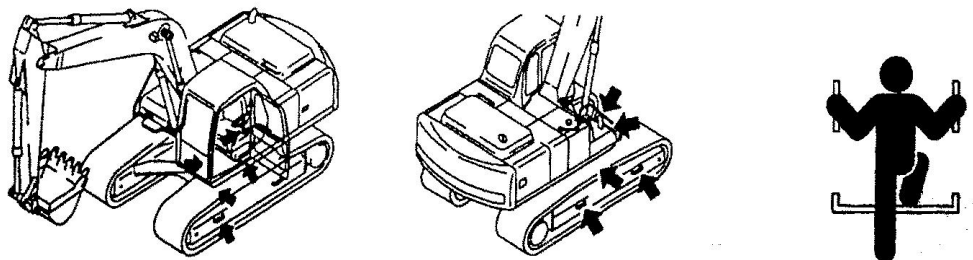

1.5 Fire protection of fuel and engine oil

Fuel, engine oil and antifreeze will ignite when exposed to open flames, so stay away from open flames or lit cigarettes.

When refueling, turn off the engine and prohibit smoking.

Tighten all fuel and oil tank caps.

1.6 Safety measures when working at high temperatures

When work is just stopped, the engine oil and hydraulic oil are at high temperatures and under pressure. At this time, if you open the cover to drain oil or water, or replace the filter element, serious burns may occur. When performing these operations, be sure to wait for the temperature to drop and follow the prescribed steps.

To prevent hot water from spewing out, turn off the engine, wait until the water cools down, then slowly loosen the cap to release the pressure, and then remove the cap. (When checking whether the water temperature has dropped, you can put your hand close to the front of the radiator to check the air temperature. Be careful not to touch the radiator.)

To prevent hot oil from spraying out, shut down the engine, wait until the oil cools down, then slowly loosen the cap to release the pressure, and then remove the cap. (When checking whether the oil temperature has dropped, you can put your hand close to the front of the hydraulic oil tank to check the air temperature. Be careful not to touch the hydraulic oil tank.)

1.7 Protection against falling or flying objects

If there is a risk of falling or flying objects hitting the driver, a guard should be installed in an appropriate location to protect the driver in each specific case.

When working with a hydraulic hammer, a front guard should be installed on the front window. Also install laminated safety glass on the front windows. (Purchased by users themselves)

When doing demolition or crushing work, in mines, tunnels or other places where there is a risk of falling objects, a front guard should be installed on the front window and a top guard should be installed above the cab. Also install laminated safety glass on the front windows. (Purchased by users themselves)

1.8 Use of accumulator

For machines equipped with accumulators, within a short period of time after the engine is turned off, when the working device joystick plate reaches the lowered position, the working device will fall due to its own weight. After turning off the engine, the safety lock lever should be placed in the locked position and the accessory pedals should also be locked with the lock pin.

The accumulator is filled with high-pressure nitrogen, which is very dangerous if not handled properly. The following safety measures should always be followed.

Do not drill holes in the accumulator or expose it to flames or naked flames.

Do not weld any bosses on the accumulator.

When disassembling or repairing the accumulator, or when disposing of the accumulator, it is necessary to drain the nitrogen from the accumulator. This operation requires a special exhaust valve. So please contact the company's sales department.

2. Safety precautions before operation

Check the construction site conditions and soil types, as well as above and below ground facilities (including underground pipes and cables) to determine the best method of operation. Work can only be carried out after unsafe environmental factors are eliminated.

Check whether there is any oil leakage in the fuel, lubricating oil and hydraulic systems. After eliminating the oil leakage, wipe up the leaked oil. Check whether the track bolts are loose and whether other parts are damaged or missing. If you find the above situation, you must not operate the vehicle.

Check the oil and water levels of fuel, lubricating oil and cooling water. Do not smoke when filling oil. Inspect and tighten the radiator cap and each oil filler cap and oil plug.

Wipe grease, oil, and dirt from the handlebars, floor, and levers. Use handrails and steps when getting on or off the vehicle, and do not jump up or down to avoid falling.

Do not leave tools and other things in the cab to prevent operations from being affected and accidents occurring.

Combustible materials such as wood chips, dead trees, branches, leaves, and paper may cause fires. They should be cleaned when inspecting the inside of the hood.

Adjust the driver's seat to the most comfortable position for operation. Do not drive the vehicle in other locations.

Before starting the engine, make sure all control levers are in the neutral position.

3. Safety precautions after starting the engine

Confirm that the performance status of all instruments and alarm devices is normal and that instrument readings are within the specified range.

Check the clearance and travel of each joystick.

Manipulate work equipment and check whether they are functioning properly.

Before operating walking and steering, pay attention to whether the track frame is facing forward or backward. If the track frame is facing backward, the method of operating the travel and steering joysticks is exactly the opposite to that of the track frame facing forward.

Before driving, sound the horn to warn people around the vehicle to get out of the way.

Drive the vehicle slowly and listen for any abnormal sounds from the engine and gears.

Drive the vehicle to a safe location, turn it left and right, and confirm that the walking and steering performance are normal.

Any problems discovered during the inspection and test run, even minor problems, must be resolved through consultation with the person in charge of the vehicle. Otherwise, the vehicle can only be driven with the consent of the person in charge.

4. Safety precautions during operation

You must pay full attention during operation and must not be careless or sloppy.

Before driving and turning, always look around to see if there are any people or obstacles in the way.

When driving on the road, the working device should be retracted as much as possible to increase stability.

Keep the bucket at a height of 40 to 50cm above the ground, so that in an emergency, the bucket can be dropped to the ground immediately and the machine stopped.

During operation, try to keep the vehicle from tilting (even when stationary, the tilt angle of the front, rear, left and right should not exceed 35 °).

行驶姿态

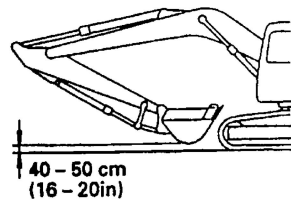

不正确

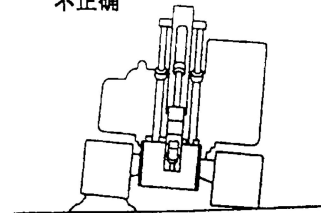

When operating on a slope, the excavator avoids turning to prevent rollover or sideslip accidents.

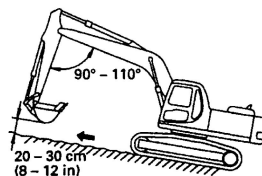
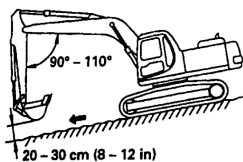

不正确

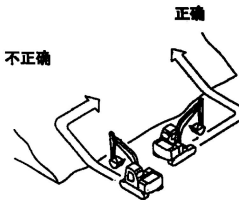

正确

The machine should be operated at normal speed and never: ① Speeding.

② Sudden start, emergency system

Move, turn suddenly. ③ Advance in a roundabout way. ④ Sliding.

During operation, always pay attention to instrument indications, changes in sound, vibration, exhaust gas color and joystick response. If any abnormality is detected, stop the vehicle immediately and take appropriate measures. Pay special attention to whether the fuel tank is leaking, as oil leakage can cause a fire.

Non-staff members are not allowed to enter the construction site.

Keep the work surface as flat as possible to increase work efficiency and ensure safety.

The solidity of the seismic layer or subsidence layer should be ascertained. After blasting, check whether there are any undetonated explosives on the ground.

When working on riverbanks or other piling areas, be careful of vehicle sinking.

When working after rain or snow, be aware that the ground will become loose and slippery, and the vehicle should be prevented from sinking or sliding.

Do not drive vehicles into mud ponds. In case you get stuck in the mud. Rescue as follows. ① If one track is stuck in the mud, turn the bucket to the side where it is stuck, use the bottom of the bucket to support the ground, so that the track is suspended, then place wood under the track, increase the horsepower and drive the vehicle out.

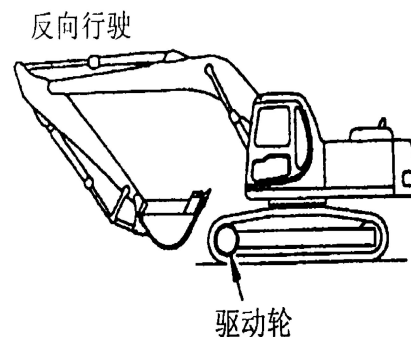

② If the tracks on both sides are stuck in the mud, first use the above method to place wood under the tracks, then insert the bucket into the soil in front of the machine, and use the folding arm method to pull out the vehicle. (At this



time, the travel and steering joysticks
are in the forward position)

Before crossing a bridge, check the load
capacity of the bridge.

When working in or passing through shallow water and swamps, first find out the
water depth, flow rate, and soil conditions. ★The water depth cannot exceed the
bottom of the vehicle turntable. ★ When working on soft soil, place some thick boards
on the ground to prevent the machine from sinking.

When visibility is poor due to smoke or fog, do not work forcefully until visibility
improves.

- When working at night, be sure to install a lighting system that is bright enough.
- ★Note the bias in estimating object heights and distances between objects at
night.

- When working between
cables, be especially
careful and always think of
the risk of electric shock.

★Wear rubber or leather
shoes.

★Set up a full-time
observation commander to
ensure construction safety.

★If you are close to a
power line at a certain
distance, you will suffer a
discharge shock. Therefore,
a certain distance must be
strictly maintained between
the vehicle and the power
line during work.

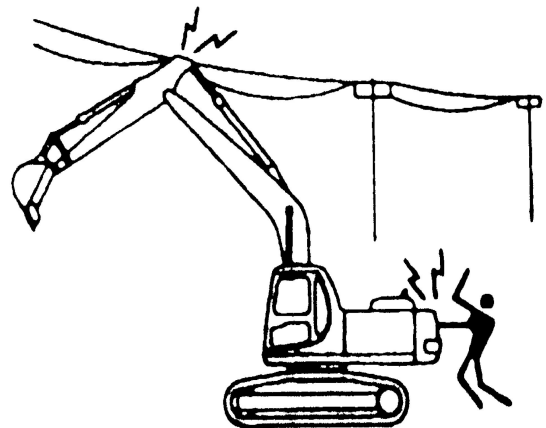

Do not dig at the bottom of the cliff or dig the soil under the machine, otherwise it will be very dangerous.

不正确

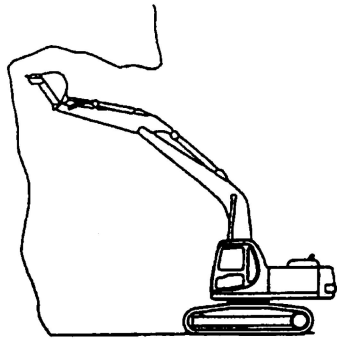

不正确

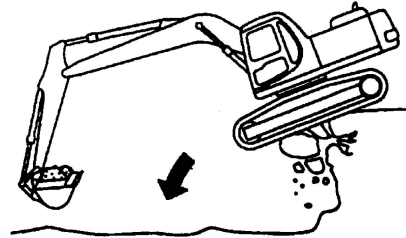

When
the
vehicle
is driving
near a
cliff,
beside a
road

low voltage	Voltage	Minimum safety distance
	100 .200V	2m
extremely high voltage	6600V	2m
	22000V	3m
	66000V	4m
	154000V	5m
	187000V	6m
	275000V	7m
500000V	11m	

shoulder, on a slope, or passing through a narrow place, if it is necessary to operate a working device, it must stop walking before operating.

When working on loose soil or prone to collapse, if the ground collapses and the machine is too late to leave the site, do not panic. You can raise the working device as soon as possible. This state is more stable than placing the working device on the ground.

During work, it is necessary to observe changes in surrounding environmental conditions at any time to prevent accidents. When rotating the bucket, be careful not to let the bucket collide with the sides of the trench and the truck body.

5. Parking of the machine

When parking, the vehicle should be parked in a safe place outside the working surface to prevent the threat of landslides, rockfalls and floods.

If the machine must be parked on a slope, chocks should be placed under the tracks to prevent the machine from moving. The working device is then inserted into the ground.

After the engine is turned off, operate the right working device joystick to the ascending and descending positions several times to release the residual pressure in the hydraulic circuit.

Before leaving the machine, make the following checks: ★Whether the rotary lock is locked. ★Whether the bucket has been placed on the ground. ★Whether the work equipment control lever has been placed in neutral and locked. ★Whether the starting key has been removed.

★Be sure to close the cab door.

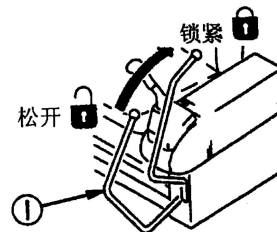
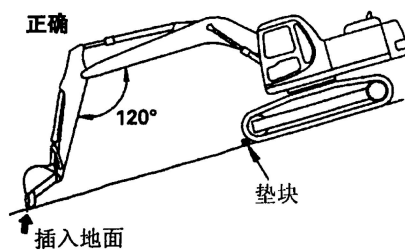

6. battery

Battery electrolytes contain sulfuric acid and batteries can produce hydrogen gas, so incorrect use can result in serious injury or fire. For this reason, be sure to observe the following precautions.

Always wear safety eyes and rubber gloves when working on batteries.

If acid is spilled on clothing or skin, flush immediately with plenty of water.

Battery acid splashed into the eyes can cause blindness. If acid splashes into your eyes, rinse immediately with plenty of water and seek medical treatment

immediately.

Before disposing of the battery, shut down the engine and turn the starter switch to the OFF position.

Avoid accidental contact between metal objects such as tools and battery terminals to cause a short circuit between battery terminals.

When installing the battery, connect the positive terminal first, and when disassembling, disconnect the negative terminal first.

When disassembling and installing, check which end is the positive pole and which end is the negative pole, and tighten the nut firmly. If the battery electrolyte is close to the lower limit level, distilled water should be added. Do not add distilled water beyond the upper limit level.

When cleaning the upper surface of the battery, wipe it with a damp cloth. Do not use gasoline, thinner or other organic solvents or cleaning agents.

If the battery electrolyte is frozen, do not charge the battery or start the engine from a different power source. There is a risk of the battery catching fire.

The battery must be removed from the chassis before charging.

The set voltage of the charger should match the voltage of the battery being charged. If the voltage is set incorrectly, it will cause the charger to overheat and catch fire, which may lead to an explosion. ★Connect the positive charging clip of the charger to the positive terminal of the battery, and then connect the negative charging clip to the negative terminal of the battery. Be sure to tighten both terminals securely.

If the battery capacity is less than 1/10 of its rated capacity, and fast charging is required, the setting value should be lower than the battery's rated capacity. If the charging current is too large, it may cause electrolyte leakage or evaporation. This may cause fire and explosion.

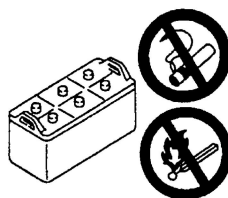

7. Lifting work

The machine is equipped with an electric winch, which can lift no more than 250 kilograms of cargo.

The electric winch is dual-operated by remote control and manual control. Voltage 12 volts,

8. Maintenance

Understand the maintenance work procedures before starting work.

Lubrication and maintenance should never be carried out while the machine is in motion.

Before starting to maintain the machine, do

- 1.) Park the machine on flat ground.
- 2.) Lower the bucket to the ground.
- 3.) Let the engine idle at low speed for 5 minutes.
- 4.) Turn the key switch to the OFF position to stop the engine.
- 5.) Pull each control lever several times to release the pressure in the hydraulic system.
- 6.) Remove the key from the switch.
- 7.) Place a "DO NOT OPERATE" sign on the control lever.
- 8.) Let the engine cool down.

If a maintenance procedure must be performed with the engine running, someone must supervise the machine.

If the machine must be lifted, the angle between the boom and the stick should be kept between 90° and 110°. All machine parts that must be lifted for maintenance must be firmly supported.

Do not work under machines that are lifted by large arms.

When cleaning parts, always use non-flammable cleaning oil. Never use highly flammable oils such as fuel and gasoline to clean parts.

Disconnect the battery ground cable (-) before making adjustments to the electrical system or welding the machine.

Precautions when adjusting track length with high-pressure grease

- 1.) Grease is pumped into the track tension adjustment system at high pressure. During adjustment, if the prescribed maintenance methods are not followed, the screw plug ① may fly out and cause damage or personal injury.
- 2.) When loosening the grease drain plug ①, never loosen it more than one turn.
- 3.) It is forbidden to face, hands, feet or any part of the body directly in front of the oil drain plug.

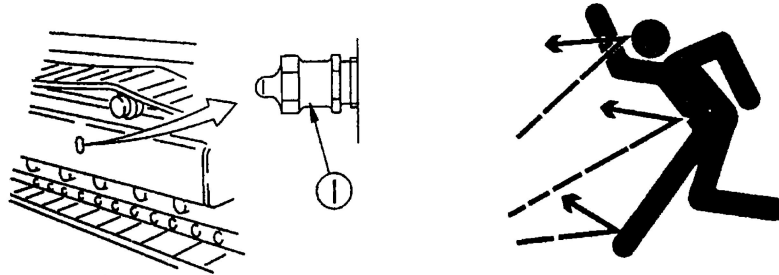

operate

1. Excavator General Picture

The directions mentioned in this section are the directions indicated by the arrows in the figure below



2. General drawing of control devices and instruments

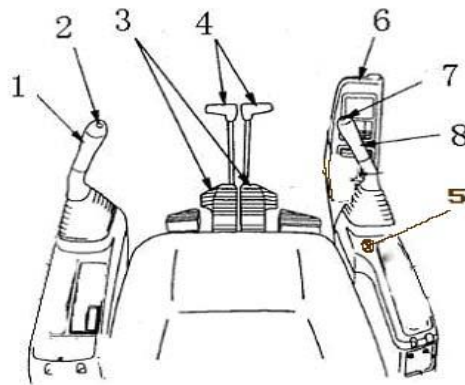

1. Left work device joystick
2. horn switch
3. walking pedal
4. Walking joystick
5. Starting switch and instrument
6. monitor
7. idling
8. Right working device joystick

3. Inspections before starting the engine

3.1 Patrol inspection

warning

A fire may occur due to leakage of oil or fuel or accumulation of flammable materials around high-temperature components (such as engine mufflers or turbochargers).

Before starting the engine, check around and under the machine to see if there are any loose bolts and nuts, and check the status of the working equipment and hydraulic system. Also check for loose wires, gap sizes, and dust accumulation in hot locations.

Check the working equipment, cylinders, connecting rods, and hoses for damage, wear, and movement. If abnormalities are found, they should be repaired.

Clean the dirt and dust around the engine, battery and radiator.

Check for water and oil leaks around the engine.

Check whether there is oil leakage from hydraulic equipment, hydraulic oil tanks, pipelines, and joints.

Check the vehicle (tracks, driving wheels, guide wheels, and guard plates) for damage, wear, loose bolts, or oil leakage from supporting wheels and rollers.

Check whether the handrail is damaged and whether the bolts are loose.

Check whether the instruments and monitors are damaged and whether the bolts are loose.

Clean the rearview mirror and check for damage.

- Safety seat straps and fixed buckles.

3.2 Inspection before starting

warning

Do not open the radiator cap unless necessary. When checking the coolant, be sure to wait until the engine is cool to check the radiator reservoir.

Check cooling water level.

Open the door on the left side of the machine and check whether the cooling water in the auxiliary water tank is between the LOW and FULL marks. If the water level is too low, add water through the water inlet to the middle level. **Check the engine oil level in the engine oil lower case and add oil.**

The oil level should be between the H and L marks on the dipstick. ★When checking the oil level after the engine is running, wait at least 15 minutes after the engine is shut down before checking again. If the machine is tilted, level it before inspection.

Check the fuel level.

After the oil filler cap is opened, the float gauge that reflects the oil level will rise. The position of the float gauge when the fuel tank is full: approximately 130mm from the top of the fuel tank. After refueling, press the float gauge vertically with the fuel filler cap. Be careful not to clip the float gauge to the fuel filler cap while closing the fuel filler cap. If the ventilation hole on the cover is blocked, the pressure in the fuel tank will drop, and this hole should be cleaned in time

Check the hydraulic oil tank.

Run the engine at low speed, retract the bucket rod and bucket cylinder, lower the boom, make the bucket teeth contact the ground, and then stop the machine. Within 15 seconds after turning off the engine, operate each joystick (working device and travel) in all

directions to the end of the stroke to release the internal pressure. If the oil level is between the H and L marks, the oil level is normal. If the oil level exceeds the H mark, do not add oil.

Note: Oil level changes with temperature. Therefore, the following two items are used as a reference.

① When the oil temperature is close to the ambient temperature (10°C~30°C), the oil level should be close to the low (L) line of the dipstick.

② When the oil temperature reaches the normal operating temperature (50°C~80°C), the oil level should be close to the high (H) line of the dipstick.

Check the electrical wiring.

Check the circuit part for short circuit, damaged fuse and open circuit. Check if the terminals are loose. Check the following carefully: ⊙ Battery ⊙ Starter motor ⊙ Alternator

Check the water and sediment in the oil-water separator and drain it.

The oil-water separator separates the water mixed in the fuel. If the buoy ② reaches or exceeds the red line ①, the water should be released according to the following **Method**:

1. Loosen the drain plug ③ and release the accumulated water until the buoy drops to the bottom.
2. Tighten the drain plug ③.
3. When draining water, if air is sucked into the fuel pipeline, be sure to drain the air in the same way as the fuel filter.
4. Start the engine •

①. Preparation before starting

Do an initial inspection. (See preparations before starting the engine for details) Place the safety locking lever in the released position.

②. Start the engine

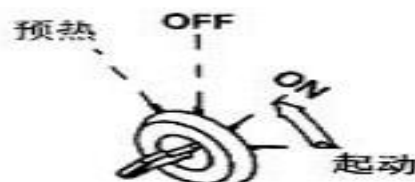
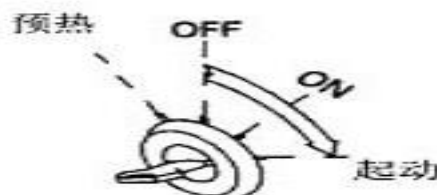

Turn the key of the starter switch to the (START) "start" position, and the engine will start.

After the engine starts, release the key of the starter switch, and the key will automatically return to the ON position.

If the engine does not start, restart it after 2 minutes.

Do not leave the starter switch in the start position for more than 20 seconds.

When starting in cold weather, keep the key in the starter switch in the preheat (HEAT) position and check that the preheat monitor light ③ should light up. After about 30 seconds, the preheating monitor light ③ goes out to indicate that preheating is complete. Turn the key in the starting switch ② to the "start" position to start the engine.

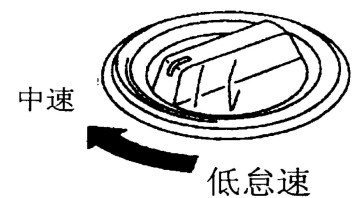
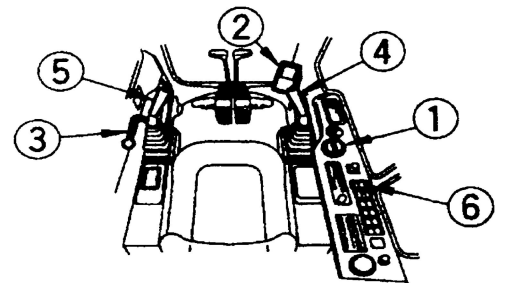

③. Operations after starting the engine

If the working equipment is operated before the engine is fully warmed up, the reaction of the working equipment to the joystick movement will be slowed down, and the working equipment will not move according to the driver's wishes, so the warm-up operation must be performed at all times. Especially in cold areas, sufficient warm-up operation must be carried out.

When the hydraulic oil temperature is lower than 20°C, do not operate the joystick suddenly. The most suitable temperature for hydraulic oil is 50°C~80°C. In order to extend the service life of the machine, the oil temperature should rise to at least 20°C before starting work.

Do not suddenly increase engine speed before the warm-up operation is complete.

Do not run the engine continuously for more than 20 minutes at low idle speed or high idle speed. This may cause the turbocharger inlet pipe to leak. If you need to idle the engine, you should add a little load or switch to medium speed frequently.

After the warm-up operation is completed, check whether the instruments and monitoring lights are in the following status: the engine water temperature gauge is in the green zone; the fuel gauge is in the green zone; the engine oil pressure monitoring light is off; the charge level monitoring light is off;

Place the safety lock lever in the released position and lift the bucket from the ground.

Slowly operate the bucket control lever and arm control lever to move the bucket cylinder and arm cylinder to the end of their stroke.

Operate the bucket and stick at full stroke for 5 minutes, and operate the bucket and stick alternately with a time interval of 30 seconds.

When the working device is retracted, be careful not to touch the chassis and the

ground.

Check whether there are any abnormalities in exhaust color, noise or vibration.

Monitor description:

The monitor mainly monitors engine water temperature, oil pressure, fuel level, machine working time, and hydraulic oil temperature. When the above data exceeds the specified limit, the buzzer will alarm.

5. Start the vehicle

⚠ Warning

Before operating the travel joystick, check the orientation of the track frame. If the drive wheel is in the front, the operation of the joystick is reversed. When moving, check that the area around the machine is safe and sound the horn before moving. The rear of the machine is a blind spot, so pay special attention when reversing.

5.1 The machine moves forward

Fold back the working device and lift it 40cm~50cm off the ground.

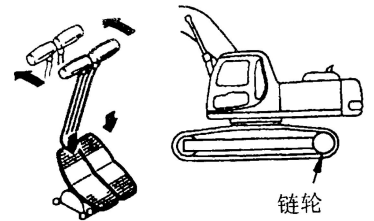

Operate the left and right walking joysticks or left and right walking pedals as follows. ① When the driving wheel is at the rear

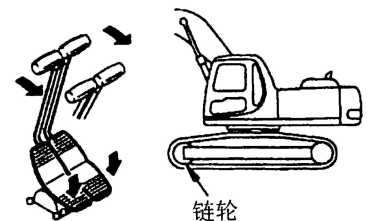

of the machine, slowly push the joystick forward or press down the front of the walking pedal. Make the machine run. ②When the driving wheel is in front of the machine, slowly pull the control lever backward, or press down the rear of the walking pedal. Make the machine run.

5.2 Steering

Use the walking joystick to change direction. To check the driving wheel Set. If the driving wheel is in the front, the operation of the walking pedal is the same.

When rotating in the left and right directions (turning on the spot), the operation is opposite. Avoid sudden changes in direction as much as possible.

When rotating in the left and right directions (turning on the spot), the operation is opposite. Avoid sudden changes in direction as much as possible.

Stop and turn.

Change the direction of the machine when parking. When turning left: When driving forward, turn left

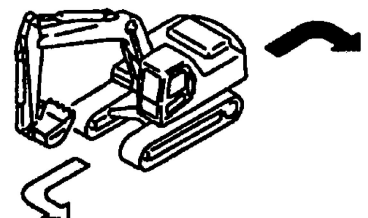
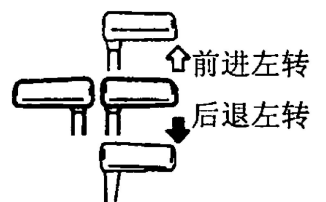
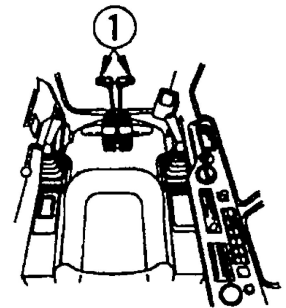

and push the right travel lever forward; when driving backward, turn left and pull the right travel lever backward. When turning right: Operate the left travel joystick in the same way.

Steering while driving (operate the left and right joysticks simultaneously in the same direction) When turning left: If the left joystick returns to the neutral position, the machine will turn to the left. When turning right: Operate the right travel joystick in the same way.

When the two crawlers rotate in opposite directions and turn (turn in place) when the two crawlers rotate in opposite directions and turn left, pull the left travel control lever backward and push the right travel control lever forward. When the two crawlers

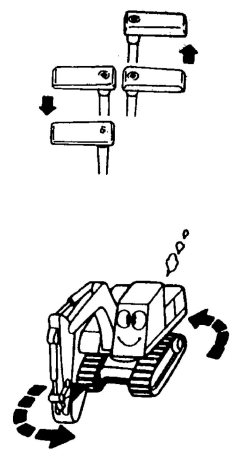
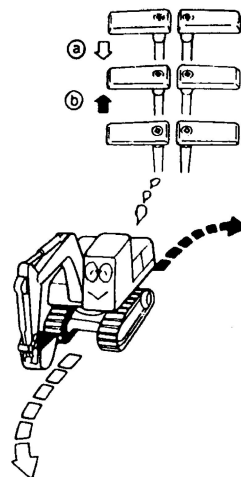

rotate in opposite directions and turn right, pull the right walking joystick backward and push the left walking joystick forward.

5.3 Rotation

When operating a swing, check that the area around the machine is safe.

Operate the left working device joystick ③ to rotate the upper structure back and forth.

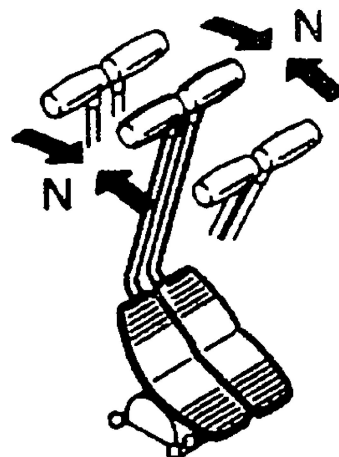
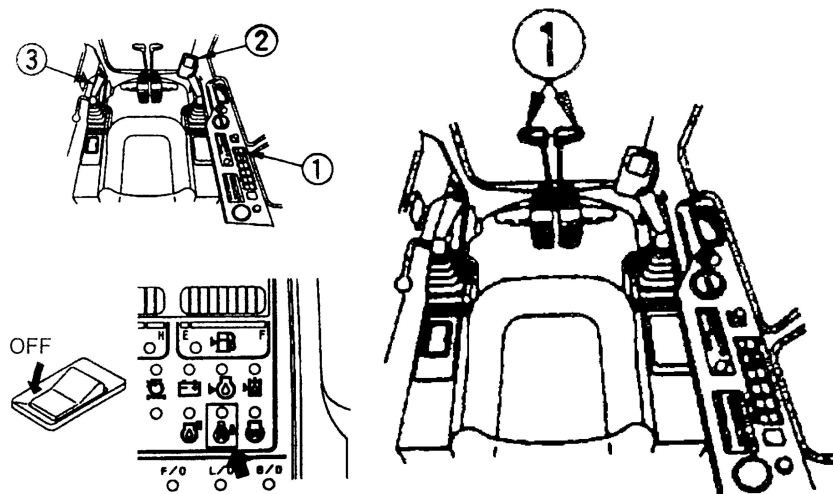

6. Machine stops

Put the left and right travel joysticks in the middle position to stop the machine.

7. Operation of working equipment

The working device is operated by the left and right working joysticks. The left working device joystick operates the bucket arm and rotation, and the right working device joystick operates the boom and bucket.

The movement of the joystick and work equipment is shown in the figure below. When you release the joystick, it will automatically return to the neutral position. The working device stops at this position.

★ When the machine stops, if the work device joystick returns to the neutral position, even if the throttle control panel is placed at the high speed position, the automatic deceleration mechanism will work to reduce the engine speed to a medium speed.

Left working device joystick position

N neutral

The stick extends.

The stick extends and

Turn right.

Turn right.

The stick is retracted and

Turn right.

The stick is retracted.

The stick is retracted and

Turn left.

Turn left.

The stick extends and

Turn left.

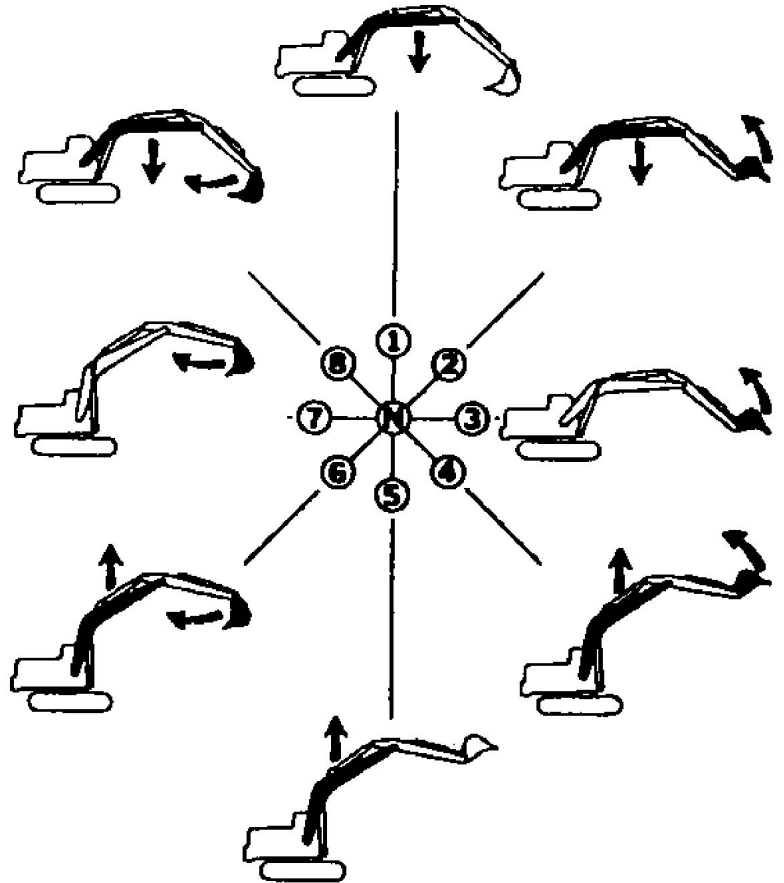

Right work device joystick position

N neutral

(1) The boom comes down.

(2) The boom comes down, 铲斗倾斜。

(3) Bucket tilts.

(4) The boom is raised,

(5) Bucket tilts.

(6) The boom is raised.

(7) The boom is raised,

(8) The bucket rolls up.

(9)The bucket rolls up.

(10)The boom comes down and the bucket rolls up.

★: **Crawler telescopic operation**

The crawler tracks can be retracted when passing through narrow roads. When retracting the crawler tracks, the handle is on the lower right side.

When retracting the track, use a bucket and bulldozer to support it so that the track is lifted off the ground.

★ **It is not a malfunction.**

Note that the following phenomena are not malfunctions

When retracting the stick, the movement speed will occasionally decrease when the stick exceeds or reaches the vertical position.

When the bucket teeth exceed or fall below the horizontal position, the stick speed sometimes decreases.

Noise is emitted from the brake valve when starting or stopping rotation.

When driving down a steep slope at low speed, noise was detected from the traveling motor.

9.Operation Prohibitions

If you need to operate the work device joystick while the machine is running, you should first stop the machine temporarily and then operate.

If the joystick is moved within

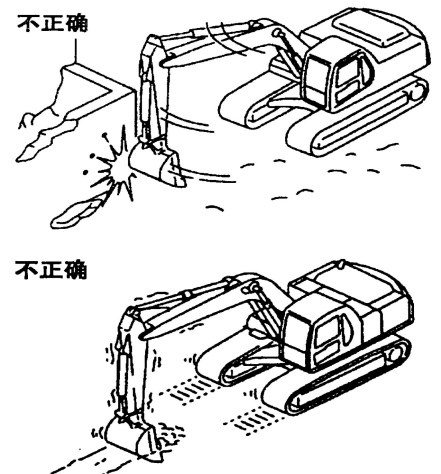

the automatic deceleration range, the engine speed will suddenly increase. Use extreme caution when operating the joystick.

Operations that utilize rotational force are prohibited: Do not use rotational force to compact soil or damage mounds and walls. When rotating, the bucket teeth may be inserted into the ground. These actions can damage the work equipment.

Operations using walking force are prohibited: Do not dig the bucket into the ground and use walking force to dig. This can cause excessive forces on the rear of the machine.

Pay attention to the operation of the hydraulic cylinder to the end of its stroke: During operation, if the hydraulic cylinder is operated to the end of its stroke, force will be acted on the gear inside the cylinder, thus reducing

the service life of the machine. To prevent this from happening, always keep a small safety distance when operating the cylinder.

Operations that utilize the falling force of the bucket are prohibited: Do not use the falling force of the bucket as a hand pick, breaker or pile driver. This can cause excessive forces on the rear of the machine. This not only damages the machine, but is also very dangerous.

Operations that utilize the falling force of the machine are prohibited: Do not use the falling force of the machine for excavation.

Excavating rocky ground: It is best to break the rocky ground through other methods before digging into harder rocky ground. This not only reduces machine damage, but is also more economical.

It is forbidden to move the joystick suddenly when driving in high gear: ① It is forbidden to move the joystick suddenly, as this may cause the machine to start suddenly. ② Avoid sudden switching of the joystick from forward to reverse (and vice versa). ③ Avoid sudden changes in the joystick position, such as sudden stops from close to the limit speed (release the joystick operation).