

Tracked Minidumper



	INDEX	Pag.
1	INTRODUCTION	3
2	MARKING	3
	ABBREVIATIONS LIST	3
3	GENERAL INSTRUCTIONS	3
4	CHARACTERISTICS	4
4.1	Machine description	4
4.2	Technical characteristics and dimensions	4
4.3	Safety prescriptions	5
4.4	Noise	6
4.5	Conformity with safety regulations	6
4.6	Operator orientation	6
5	NEW WORK SITE	6
5.1	Transport	6
5.2	Placing and how to park the machine	6
5.3	Areas of respect and dimensions	7
5.4	Pre-operation check list	7
5.5	Safety list	7
5.6	Puts in job	7
5.7	Training	7
6	REGOLATIONS	7
6.1	Regulation of the machine	7
6.2	Regulation of the rubber track	7
7	USE	8
7.1	Operation and commands	8
7.1.1	<i>Move of the machine (Joy stick A and B)</i>	8
7.1.2	<i>Manoeuvres tools support</i>	8
7.1.3	<i>Accelerator lever (A)</i>	8
7.2	Use of the endothermic motor	8
7.2.1	<i>Controls before starting</i>	8
7.2.2	<i>Starting</i>	8
7.2.3	<i>Turning off</i>	8
7.3	Preheating of the machine	8
7.4	Machine transfer	8
7.4.1	<i>Rectilinear transfer</i>	9
7.4.2	<i>Transfer</i>	9
7.4.3	<i>Instructions moving</i>	9
7.5	General instructions	9
7.6	In action on the work site	9

	INDEX	Pag.
7.6.1	<i>How to stop the machine</i>	10
7.6.2	<i>How to leave the machine</i>	10
7.7	Lifting of the machine	10
7.7.1	<i>How to lift the machine</i>	10
7.7.2	<i>Upload and downloading the machine</i>	10
7.7.3	<i>On the mean of transport</i>	10
7.7.4	<i>Block for the transport</i>	10
7.8	Parking machine	10
7.8.1	<i>Parking of the car</i>	10
7.8.2	<i>Under conditions of col</i>	11
8	MAINTENANCE	11
8.1	Ordinary and extraordinary maintenance	11
8.2	Daily maintenances	11
8.3	Weekly maintenances	11
8.4	Maintenances every 250 H	11
8.5	Maintenances every 500H	11
8.6	Table of lubrication	11
8.7	Controls and maintenances	12
8.7.1	<i>Control tension tracks</i>	12
8.7.2	<i>Track maintenance</i>	12
8.7.3	<i>Controls and daily maintenances</i>	12
8.7.4	<i>Filling fuel</i>	12
8.7.5	<i>Controls and maintenances every 50 H</i>	12
8.7.6	<i>Controls and maintenances every 250 H</i>	12
8.7.7	<i>Cleaning cup fuel</i>	12
8.7.8	<i>Substitution filter</i>	12
8.7.9	<i>Substitution filter</i>	13
8.7.10	<i>Control and maintenance every 500 H</i>	13
8.7.11	<i>Parking for a lot of time</i>	13
9	PROBLEMS, PROBABLE CAUSES, FOR MALITY OF INTERVENTION	13

1. INTRODUCTION

The following manual is turned to the personnel that has the responsibility of the correct use of the machines it regards the safety aspects. Recommends therefore a careful reading, especially of the paragraphs related to the instructions and to the formalities of use, to possibly preserve him/it in his/her custody together with the mini-dumper, so that to assure its availability for the following consultations. The machines provided of devices and safety systems opportunely studied and tested.

2. MARKING

The machine is identified with a special label in which there is write:

- CE mark in conformity to how much suitable in the directive 98/37/CE, attached II, part A; - Year of manufacture;

ABBREVIATIONS LIST

Cap.	Chapter
Par.	Paragraph
All.	Enclosure
Mod.	Model
Rif.	Reference
D.M.	Machine Directive
Machine	Set of parts or components of which at least one mobile, interconnected, with appropriate actuators, control and power circuits, joined together for a very specific application in particular for the processing, treatment, handling and packaging material (D.M. 98/37/CEE - 98/79/CEE)
Dangerous zone	Any zone to the inside e/o in proximity of a machine in which the presence of an exposed person constitutes a risk for the safety and the health of said person. (D.M. 98/37/CEE - 98/79/CEE)
Exposed person	Person that are entirely found or partly in a dangerous zone. (D.M. 98/37/CEE - 98/79/CEE)
Operator	Person or people entrusted of to install, to make to work, to regulate, to perform the maintenance, to clean, to mend and to transport a car. (D.M. 98/37/CEE - 98/79/CEE)
Safety	Is in which the risk of damage to the people or to the things is limited to an acceptable level (EN 8402 and 94)
Risk	Combination of probability and gravity of possible lesions or damages to the health in a dangerous situation (EN 292/1)
Danger	Source of possible lesions or damages to the health (EN 292/1)
Evaluation of the risk	Global evaluation of the probability and the gravity of possible lesions or damages to the health in a dangerous situation to choose the suitable safety measures (EN 292/1).
Fixed protection	Shelter maintained in position, or in permanent way or through elements of fixing (EN 292/1)
Harmonized norms	European norms submitted by her/it Us and recalled by directives.
Preventive maintenance (ordinary)	Maintenance performed to predetermined intervals or in accord to prescribed criterions and time to reduce the probability of breakdown or the degradation of the operation of an entity (CEI 56/50 and 97).
Maintenance corrective (extraordinary)	Maintenance performed following the survey of a damage and time to bring an entity in the state in which it can perform an in demand function (CEI 56/50 and 97).
	Attention: instructions and indications to meticulously be followed.

3 GENERAL INSTRUCTIONS



- Safety of employment of the machine is guaranteed only for the functions listed in these instructions of use.
- For operations of extraordinary maintenance and reparation you must be use only original parts.
All these operations must be performed Out of the machine, in a proper place, in plain and predisposed
- . The whole personnel that can be involved in the use to different title, has to be educated for a correct use, so that to never jeopardize neither the proper one neither other people's safety.
- Needs that the operator reflects on the possible consequences before drawing near with the hands, particularly
- **DON'T MAKE PEOPLE CLOSE AROUND(DISTANCE 2 METERS).**
- **DON'T SUPPLY THE FUEL WHEN THE MACHINE IS ON**
- The machine has a considerable metallic mass don't use when it storms **THUNDER IS CAUSE OF DEATH!**
- Follow particularly the safety indications:
- Use the individual protections as gloves, bonnets masks during the use, for assembling and maintenance.
- Setting particular attention to the parts in movement..
- Follow the safety indications brought in the chapter Indications For The Safety

4. CHARACTERISTICS

4.1. Description of the machine

The Mini dumper is built for the construction. Up to the machine there is the multifunction vessel : From the factory it goes out in the proper order for to transport material loose as: soil, manure, leaves, sand, grain and similar. Operating the special lever is gotten the inclination of the vessel , the lever of closing counter in low to the left some large case automatically opens, getting I unload him/it some transported material..

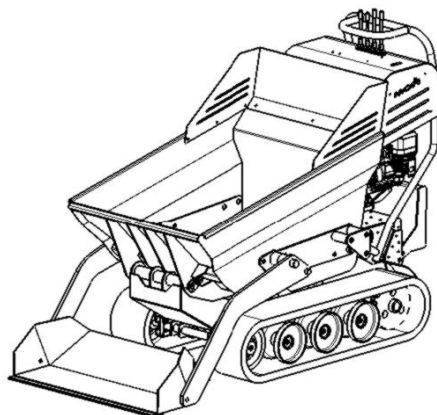

The main characteristic of this machine are : to be very simple, strong, reliable.

The small dimensions, the particularity of the loom, allows him to operate on every type of ground guaranteeing safety, stability and reliability in the time. A rapids verification to the morning will guarantee you a believer and sure companion of job for the whole day. The operating levers are situated in such a position that allows good visibility in any position and the operator it has the full control of the commands.

4.2 Technical characteristics and drawing

Technical data MACHINE :

Description	Measure	
Weight	Kg	345
Payload	Kg	350/500
Engine		170F
Max speed	Km/h	2,88
gradeability	% (°incl.)	36% (20°)

Description	Measure	Diesel Version
Peso a vuoto	Kg	361
Portata utile	Kg	350/500
Dati Motore		
model		KAMA178FE
Max speed	Km/h	2,88
Pendenza massima superabile	% (°incl.)	36% (20°)

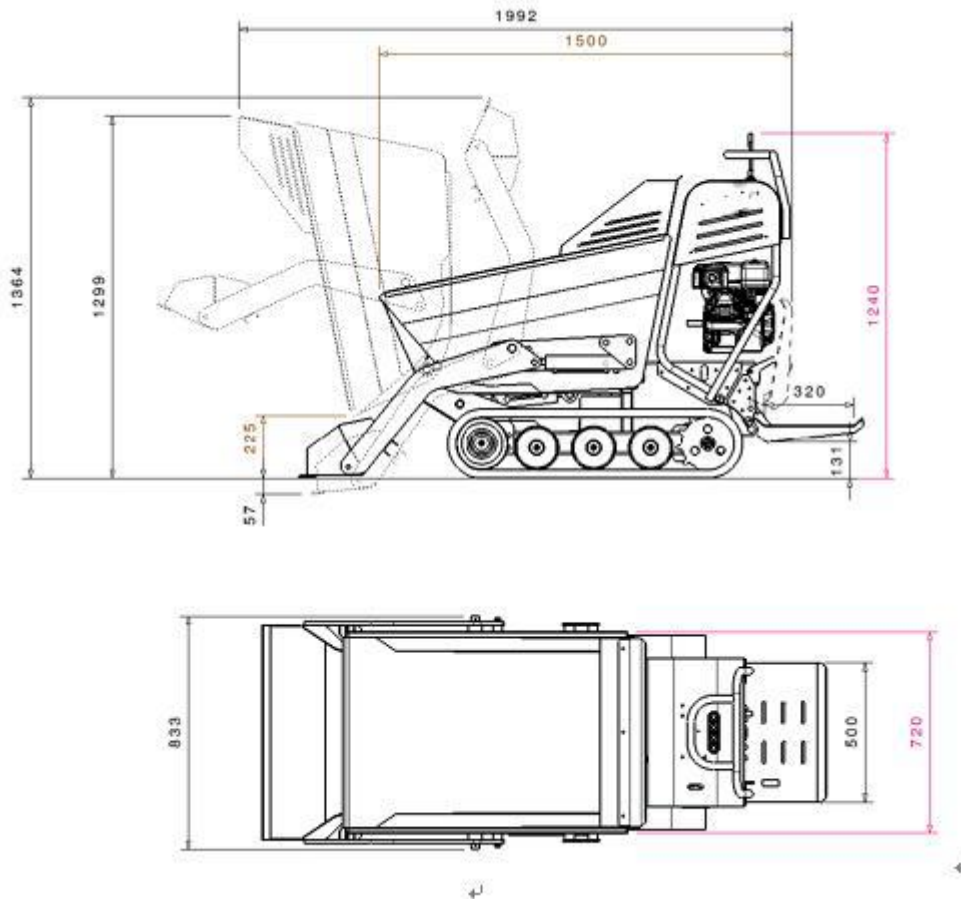

4.3 SAFETY PRESCRIPTION *Limits of use, space*



The machine has been designed and built for being used in external environment or in closed environments but airy. The machine is not fit for the use in underground places, environments with presence of gas, dusts, explosive.

The machine has been designed and built for transport of loose materials what: soil, manure, leaves, sand, stones, gravel, grain and similar, firewood, flowerpots, baskets, cassettes for fruit, vegetables and other products of the agriculture and floriculture. The mini-dumper are studied, designed, to transport the material solos above described. Be careful driving in reverse.

Always check the ground so that to avoid unexpected obstacles. Operate only in safety condition.

Don't bring changes to improve the machine performances.

Not reverse the sense of march, if the machine is in movement you can be cause of accidents.

Driven always to moderate speed, before reversing the march stop you, check that there are no obstacles and you leave again.

You attentively check the ground on which work: holes, terrestrial yielding, hidden stones, cables voters, pipelines of the gas or the water etc. can represent a danger To always operate to checked speed; in case of steps to be overcome, you always insert some additional thickness between a stair and the other because they limit the bumps.

You never make descents to the limit of inclination in reverse.

If the machine is used with terrestrial inclination, assure you that the tracks are oriented in the sense of the inclination and not transversally.

Working on a soft ground, uneven or not leveled it is necessary to set greater attention to avoid the turnover.

Never overload the machine ! You could capsize and provoke serious accidents.

Before climbing with the MACHINE on ramps, check that these are sure of the suitable course, that is not slippery.

To avoid the superior inclinations to 20°.

Follow the instructions of the manual for a correctly park of the machine.

The gasoline is inflammable. You always extinguish the machine before the restocking and allow to cool.

Not use the hands for the control of the small oil leakage, neither to hold the to use a cardboard to check on this I complete the possible presence of hydraulic liquid.

Always remember that the oil is a special refusal and as such managed to terms of law.

If a particular situation brings you to use the machine on the border of a road or on a slant, worry to check you first the level of the ground and the equilibrium of the machine, to avoid a possible glide or a turnover.



ATTENTION !!!!! . EVERY WRONG USE OF THE MACHINE OF THAT EXPECTATION IS DECLARED AT THE BUILDER IN THE MANUAL PRESENT IT IS CONSIDERED IMPROPER.

4.4 Noise

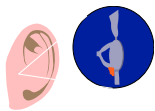

In the underlying chart are brought::

- the level of noise issue of the mini-dumper. measured to the ear of the operator (LpA to 1 m in conformity to how much foreseen by the Directive 98/37/CEE)
- the level of noise issue in the environment (power LwA) measured following EN ISO 3744 (2000/14/CE)

Tracked mini-dumper	Motor	LpA (dB)	LwA (dB)
Gasoline	170F	76 dB	93 dB
Diesel	KAMA178FE	79 dB	98 dB

Don't increase the time the level of noise it is necessary to meticulously respect the following rules:

- Clean, lubricate and to fatten up with the recommended frequency the organs of the machine. Check that is not obstructed or damaged parts of the machine. The level of noise it is obligatory the use of devices of individual protection as bonnets, corks present quant'altro in commerce to protect the hearing. The values rated for the noise are levels of issues and not necessarily levels of sure job. While there is being a correlation between levels of issue and levels of exposure, this cannot reliably be used for determining if they were in demand or no further precautions. The factors that influence the reality level of exposure of the worker include the duration of the exposure. Her characteristics of the environment, other sources of issue for ex. the number of the cars and other adjacent workmanships. Also the levels of exposure permissions can vary from country. However these information put in degree the user of the machine to make a best evaluation of the dangers and the risks.

4.5 Safety normative conformity

HUKI 40 H is projected and built in conformity to the following norms:

"Direttiva machine" 98/37/CEE - and relative changes and to the legislation that transposes;

- **Direttiva 2000/14/CEE "environmental acoustic issue of the Mini-dumpers and equipment destined to work to the open one" and to the national legislation that transposes;**
- **" Procedures applied for the evaluations of conformity: check inside of the production with evaluation of the technical documentation and you check periodic, all.**

4.6 Directional references In all the cases in which it refers us to in this manual: right and left, before and back, he intends bewareing of the position of the operator with the Large case of the Bill conveyor of forehead.

5 NEW WORK SITE

5.1 Transport

The mini-dumper is delivered assembled and functioning, for which it is enough to unload to load the machine with fit platforms or on a Pallet.

The solidity of the mini-dumper, their form and dimensions, are such to be guaranteed the portability and the stored in sure way and without damages. To load and to unload with a lift and pallet suitable to the load. For the machine to go down from the pallet is simple, all it takes is slowly moving it and with attention. The weight of the mini-dumper is brought on the nameplate Us; being a remarkable weight to watch out a lot of in phase of load and unloading. Assure you that the mean on which transport the machine and the possible ramps of load, have measures and course adjusted, above all that they have such a dimension to also allow the passage of the operator. you always Stop the wheels of the truck with some wedges before loading or to unload the machine. You fix the ramps to the truck and you conduct the machine on the same with due caution.

Switch off the engine, removes the ramps and ties the machine to the mean of transport in sure way.

The machine has stung specific of anchorage and lifting, suitable with adhesive, therefore tied up labels with straps the loom.

The mini-dumper has these :

- N .1 Operator and spare parts manual
- N. 1 Engine book;
- N. 1 funnel for the restocking fuel;
- N .1 Certified of conformity C.E. attached in this manual



We recommends to adopt every caution during the operations of load-unloading and transport so that to avoid damages and dangers to the people and the car. The devices of load and transport have to be dimensionati and confirmed in conformity to the weight to sustain. To lift the car, to use fit ropes and to hook only him in the suitable points. To follow the safety indications brought in the chapter Indications For The Safety.

5.2 As to leave the machine

The mini-dumper has to be placed in a suitable zone.

5.3 Areas of respect and dimensions



The useful space of necessary job to a correct use and to a correct maintenance is of minimum 5 meters in which the zone of respect is brought around the car, inside which it is necessary to pay the maximum attention both for the people and the things, avoiding that there can be obstacles during the use. **Inside the zone of respect it is necessary to pay the maximum attention to the people and things, avoiding that can be present obstacles to the passage. To use devices of individual protection as shoes antinfortunistiche and to handle the periodic cleaning of the floor.**

5.4 Pre-operation check list



With the commands to hydraulic driving it is **EXTREMELY IMPORTANT** that, before beginning the job, the hydraulic oil is heated. During the phase of heating the operator can verify the correct operation of the machine or the possible necessity of maintenance.

This manual, the nameplates on the machine furnish the necessary indications for a correct and sure operation of the car. And' your care to read and to understand such indications, in how much ignoring you can cause her serious accidents. Not you leave to the case if there is something that you not understand. Your distributor will be pleased to give you any necessary information. In the case of dismay or damage of the manual, of the nameplate or of the labels, you contact your distributor for the substitution.

5.5 Safety first of all



All the mini-dumper can be dangerous. When are used and correctly maintained, it is an extremely sure car. If you/he/she is wrongly used, you/he/she can result instead dangerous. Both in this manual and on the machine you will find some instructions, indicating all the potential dangers and as to avoid them. For any doubt, asks explanations to your retailer or to your responsible forehand. Not you work with the machine until don't be able to check her/it. Not begin some job up to that you are not certain of yours and of other people's safety. You could incur in accidents if you perform some non family operations, without doing before the tests, that must be perform in the free zones away from other people and on plain ground. Follow the safety prescriptions (see 4.3 INDICATION PRESCRIPTION).

5.6 puts in job



Before the mass in work of the machine, especially if it deals with the first starting or when this is installed in a new place of employment and' necessary to effect the following verifications and to keep in mind of the following technical instructions and the following suggestions:

Verify the level of the oil; - to Verify the state of use of the tracks; - To verify the areas of respect and the work areas;- Verify that the protections have correctly fixed;
Verify that the indications and the instructions are present on the machine and easily visible.
Effect a general test of all the commands of the car, to empty to verify its correctness

5.7 Training



Before the use of the machine it is necessary to attentively read this manual of instructions learning the formalities and the procedures to operate in safety.

6 REGULATIONS

6.1 Regulation machine

To the first use in the yard, the car doesn't need regulations.

6.2 Regulation rubber tracks

Regular often the tension of the tracks.

- An insufficient tension can make to go out the tracks of its own center and it quickly consumes the wheels engines and the metallic inserts of the track.
- An excessive tension increases the resistant strength to the transfer and this can cause both an excessive wearing out of the bottom wagon is an extra tension of the track with possible premature breakups.

To prevent possible damages to the tracks in rubber would need to avoid to work the more possible in the following situations:

Cave or pointed rocks. - Bars or metallic wrecks.

Edges or edges of metallic objects or cement. - Fire or other sources of heat.

To eliminate the with a rag: gas-oil, hydraulic or fat oil from the surface of the track.

If the machine is not used for long time (3 months or more) to store the tracks avoiding the direct light of the sun and the rain.

Because of the characteristics of the rubber to use the car with inclusive temperatures among -25°C and +55°C.

7.USE

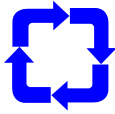

7.1 Operations and commands

7.1.1 Move of the machine (Joy stick A, B)

Move rectilinear

Push the two levers and the machine start moving

Stop

Leave the levers and machine stopped.

Turning off

Throw back the levers.. Machine move to the back part (operator side).

Don't drive or move the transporter when is switch off.

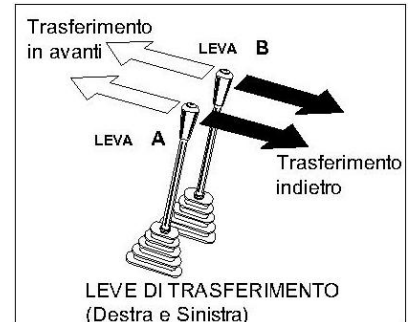

7.1.2 Manoeuvres vessel (D)



Attention !!

When motor is switch off, the lever D t lowers under same weight.

Lift vessel:

Push the lever in ahead to capsize vessel

.Lower vessel:

Throw back the lever to bring the vessel in horizontal position..



7.1.3 Speed Lever (E)

Decelerate

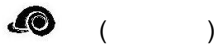

Push the lever in ahead to lower the turns of the motor.

Acceleate



Bring back the accelerator lever to increase the turn of the motor.

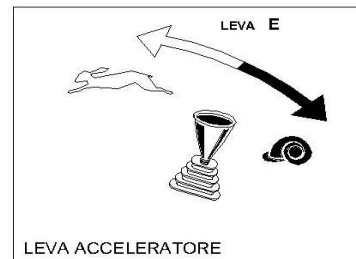

During the useof the machine follow the chapter SAFETY LIST.

7.2 Use of endothermic motor

7.2.1 Controls before starting

Verify the levels of oil motor and fuel..

For the methods of control , make reference to how much brought in the section "daily Controls" of this manual.

7.2.2 Starting

Effect the mass in motion of the motor reporting suggestion by the builder of the motor reading the special manual, of which the machine is equipped.

7.2.3 Turning off

- Rotate the Lower part motor Turns for some minutes. This allows the motor to gradually get cold before the turning off.
- Effect the turning off of the motor reporting suggestion by the builder of the motor reading the special manual, of which the machine is equipped.

7.3 Preheating of the machine

As for all the hydraulic systems, it is very important that the hydraulic oil is to thermal regime before beginning to work.

The necessary time to the preheating can usefully be employed for some simple operations of control of maintenance. Before effecting height manoeuvres load meticulously follow to the following indications:

- Leave that the motor slowly heats him to low regime of turns for 2-3 minutes.
- Operate the cylinder of lifting of the vessel to heat to allow the filling of the pipelines.

7.4 MACHINE TRANSFER

7.4.1 Rectilinear transfer

1. Move the lever of regulation of the number of turns of the motor in the desired position.
2. Control the lever:

Rectilinear transfer

Push the lever and the machine go straight on

- STOP

- Move back slowly both the levers up to the intermediary position to brake and to stop the machine

Transfer reverse

Pull the lever and the machine go back

7.4.2 Transfer control

1. Move the lever of regulation of the number of turns of the motor in the desired position.

Check the levers of right transfer and it damages as it follows.

CURVILINEAR TRANSFER

Follow the underlying indications :



Bend to the left Push the right lever (1) ahead to rotate to the left moving, to throw to if the right lever to rotate to the left moving back

Bends to the right

Push the left lever (2) ahead to rotate to the right moving himself/herself/itself in before, the left lever to rotate to the right moving back.



3 Rotation on him same

Rotation to the left

Push in before the right lever (1) and contemporarily to throw back her it raises left. (2). This operation provokes to the left a fast rotation



Rotation to the right

Push in before the right lever (1) and contemporarily to throw back her it raises left. (2). This operation provokes to the left a fast rotation



7.4.3 INSTRUCTIONS FOR MOVES ON THE GROUND IN INCLINATION

Lower the regime of turns of the motor when you maneuver in narrow spaces or climbing over a ditch. On a ground in inclination to possibly move himself/herself/themselves with the tracks prepared in the sense of the inclination and not transversally. Not on the wrong side goes never to a slant. You avoid to change the sense of direction on the slant, this you/he/she could cause the turnover or side skid of the machine.

Attention to the strong inclinations, the builder of the endothermic motor has inserted an electric sensor that spenge the motor so that to avoid lack of lubrication, caused by the excessive inclination (max 25°)

7.5 General Instructions

• Use where the devices of individual protection in demand

- Is forbidden to transport people.
- Don't put in the large case of the so voluminous loads to be able to hinder the view from the place of guide.
- Don't circulate with the lifted large case.
- Don't insist on the joy sticks when the large case is aloft to end run or in low.
- Don't brake or to brusquely steer to high speed .
- Don't bear the intervention of bystanders in the ray of action of the machine
- At the end of every cycle of job, to worry himself/herself/themselves that the inside of the large case is clean. To lift the alone large case on solid or level ground.
- Maintain on the strong inclinations, the turned loaded large case always awry.

Every time that he abandons the mini-dumper , to leave him/it in safety, or rather with lowered large case, out motor and I brake mechanic of inserted parking.

7.6 In action on the place of job

- Worry during every manoeuvre not to put to risk of it the proper of it other people's safety.
- Avoid every abrupt manoeuvre, particularly on uneven and slippery runs.
- Avoid the manoeuvres in descent with motor to tall regime of turns.

- Avoid to insist when the large case is aloft to end run or in low.
- Lift the alone large case when the machine is on terrestrial sure and level.
- Always avoid to unload with side inclinations, but to line up the machine in direction of the inclination.
- Progress with prudence in proximity of ditches, excavations, terrestrial yielding and similar.
- Verify every new run and to watch out for the points covered by grass, leaves or other.
- Reduce the speed and load on the most binding runs.

Progress with the turned large case awry when, to load, strong slopes and descents are faced.

7.6.1 As to stop the machine

You softly leave the levers of transfer and stopped you. The motor must be allows to turn to empty slowly for about 2 minutes before switch off.

7.6.2 As to leave the machine

You park the machine in a plain zone, don't leave never her in descent or in the dangerous zones. The machine is equipped of brake of manual parking, that you will have to insert for having the certainty that the machine doesn't stir.



7.7 Lifting of the machine The missed respect of the following rules can provoke serious damages, accidents or death.

Not you ever haul the mini-dumper. You use fit means for the transport. You use cables and appropriate tools for the lifting. The cables of lifting have to have an enough length to avoid the contact with the machine. To use organs of lifting suits for to bear the weight of the machine. Do never lift the machine with personal on board. To use cartellonistica and others you signal to delimit the zone of load. To always use cables and other devices with superior loads of breakup to 4T.

7.7.1 PROCEDURES OF LIFTING

On the machine they are anticipated points of hookup but you/he/she can be lifted through muletto making to climb on her/it on a pallet.

1. Give a sure and strong pallet to sustain the weight of the conveyor.
2. To position in a plain zone and with the empty large case and in lowered position to make to climb the machine and to center
3. .Stop the motor.
4. Verify that there are not obstacles or people around the machine.
5. .Lift the pallet with the machine from the ground of few centimeters and to verify that is well balanced.
6. Always transport however her to few earth centimeters, not to stir in reckless way and with the tall load from earth.

7.7.2 LOAD IS UNLOADED OF THE MACHINE



To load and to unload the machine, if possible, on terrestrial leveled and stable. If unloaded with Ramps, to use a ramp of enough length, width and thickness to bear the weight of the machine and at the same time allows the passage of the operator.. To avoid glide verified that them no is slippery. Never change direction on the ramps of load, to maintain a rectilinear transfer.

7.7.3 LOAD OF THE MACHINE ON THE MEAN OF TRANSPORT

To load and to unload the machine, if don't have a muletto to load her/it on a pallet, to Always use the ramps and to attentively follow the following procedure.

1. To stop the wheels of the truck before loading the machine.
2. To lower the banks of the truck.
3. To stop in safety the ramps to the truck. The ramps have to form with the Terrestrial an inferior angle to the 15°. The width of the ramps has to be Adjusted to the tracks and they have to foresee the passage of the operator.
4. to position the machine so that is found of forehead and with the parallel tracks to the ramps of load. Not do use anybody lever, excluded those of transfer, when her machine is found on the ramps of load.o maintain the center of gravity of the machine inside the area of the ramps of load.

7.7.4 BLOCK FOR THE TRANSPORT

1. Switch off the motor
- o insert the mechanical brake of parking and to assure the machine to the structure of the truck in opportune way.

7.8 PARKING MACHINE

At the end of every day of job it is necessary to follow the following procedures:

7.8.1 PARKING OF THE MACHINE

To conduct the machine in a sure place with flat ground.

1. Reduce the speed rotation of the motor..

2. Always lower the large case not to leave ever lifted before switch off the motor
3. Insert the mechanical brake
4. Switch off the motor,.



7.8.2 Under conditions of cold

If are anticipated temperatures of strong cold both the tracks they have to be clean from the mud and from the dirt, the machine you/he/she must be parks on the wood tables.

MAINTENANCE

The machine doesn't ask for particular operations of maintenance. The technical solutions and the used components are such to be reduced the interventions of maintenance. However recommend him to perform a whole operations that you/they have the purpose to guarantee the safety, the reliability and the efficiency of the machine in the time.

During the maintenance

- Intervenire sulla macchina solo dopo averla collocata/parcheggiata nella zona definita al punto 5.2
- In caso di problemi di tipo meccanico o elettrico, rivolgersi a un officina autorizzata.

To intervene only on the machine after having park in the zone defined to the point 5.2 In case of problems type mechanic or electric, to turn to an authorized shop. If the machine is off duty because of breakdowns, maintenance or reparation, to signal with special poster. To always " use the devices of individual protection during the reparation and substitution of the elements of the machine. Interventions on the motor must be perform only from specialized personnel and authorized. Don't introduce the hands, the arms or parts of the body in proximity of the zone of movimentazione and transmission. Use a suitable device to remove possible deposits (brushes, wood extremity etc.): not to use only never the hands!

A regular maintenance prolongs the life of the machine, it assures the best performances and it constitutes a safety important factor. **8.1 Ordinary and extraordinary maintenance**

- To " clean the filter of the air after the first 50 hours , in case of job in environments a lot of dust , cleaning daily.
- To " verify the presence of possible losses of hydraulic oil.
- To " verify the serraggio of the whole bulloneria, particularly to daily check the tension of the tracks.
- To " replace the oil motor and to perform the other operations foreseen by the manufacturer of the motor (to see book education of the motor furnished in enclosure to the manual present)

To " perform all the operations of maintenance daily, weekly, fortnightly and following following you list.

8.2 MAINTENANCE : daily perform at the end of the job

To eliminate every anomaly that was manifested.

- Clean the interior vessel
- To fatten up all the points of lubrication, with firm motor and large case in position of rest.
- To attentively verify the state of the tracks.
- To verify if during the job losses of oil or fuel are verified, it is enough to give a glance to the organs of the machine, not they owe us to be stains that you report some losses.

8.3 MAINTENANCE : weekly

- Clean the element air filter motor and lowered large case.

8.4 MAINTENANCE :every 250 hours work

- To " replace oil motor to see the instructions of the manufacturer of the motor.
- Clean the cartridge of the filter fuel.
- Replace the element I filter air.
- Replace the cartridge filter hydraulic oil..



8.5 MAINTENANCE every 500 hours work

- To " replace oil motor to see the instructions of the manufacturer.
Replace hydraulic oil.

To always remember himself/herself/themselves that the oil is a special refusal and as such managed to terms of law. Alternate him proposed they are tied up to the type of environment in which the machine is used, very dusty environments they for example ask for more frequent interventions of cleaning of the filter air.

8.6 TAVOLA DI

RECOMMENDED LUBRIFICANTS

Position	Quantity	Frequency	Characteristics
----------	----------	-----------	-----------------

170F ENGINE	Max. 0,6 lt	250 HRS (In beginning 20 hrs)	SAE 10W-30
HYDRAULIC OIL	Capacity 16 lt	500 hours	HYDRAULIC OIL LONG DURATION ISO N° 46

8.7 CONTROLS AND MAINTENANCE IF NECESSARY

8.7.1 Control tension tracks

1. Screw the die anteriorly set up to that the tension of the track has not returned to that volute.
2. T conform the tension on both the sides, to move the minidumper before and back and to verify again the uniformity of the tensionamento.
3. Verify at the end that both the tracks are tense equally, otherwise to repeat the operations.



8.7.2 Rubber tracks maintenance

Rubber tracks needs to be changed or revised as follow indications

1. Height of the outrider The rubber tracks can be used even if worn, however if excessively consumed, the tracks can skid and therefore to apply a greater application of power to the motors of traction. If the remained outrider is inferior or equal to 5 mm is advisable to replace the track with one new original.

2. Exposure of the steel ropes If the steel ropes of a track in rubber are exposed because of an excessive usury or for damages, to replace the track with one new original

3. Cut of the steel ropes of the tracks in rubber.

When a cut is noticed in the steel ropes to immediately replace the track. If the substitution is not effected keeping on working you/he/she can happen that the track breaks him completely to the sudden one and this can provoke accidents and the lock machine if don't have an exchange

4. Cracks on the coverage in rubber

If a crack of 30 mms is visualized or more than length and 8 mms or more than depth, to immediately mend the rubber. If the steel ropes appear even if the crack is smaller to immediately mend the track. Otherwise the water that enters the crack can rust the steel ropes or to provoke the breakup of the track.

8.7.3 Formalities of control of the level hydraulic oil

Always clean the zone around the cork before removing him/it. Do never overcome the maximum level of hydraulic oil in the reservoir. Never use the machine when the level of the oil overcomes the maximum one (full) e/o when inferior to the least one (to add).

1. to position the machine on plain ground with piston of the completely wide large case.
2. Verify that the level of the oil is correct.
3. If necessary add oil
4. Clean and to put again the cork loaded oil B. Per to bring in pressure the reservoir to make reference to the section "substitution hydraulic oil" of this manual cap 8.7.10.

8.7.4 FILLING RESERVOIR FUEL

To add the fuel, spengere the motor, to remove the cork set above the reservoir of the gasoline pointed out with special label to proceed to the addition of the necessary fuel using the funnel in endowment. After the restocking to make sure himself/herself/themselves to have closed again well the cork before putting again in motion. Attention!! to Use only gasoline without lead.



8.7.5 Controls and maintenance every 50 hours

eaning element filter air. To perform the maintenance of the filter of the motor air extinguished for avoiding damages to the same. Don't clean the elements filter with hits or bumps (not to beat him/it). not to use elements filter with damaged parts to prevent damages to the motor. When the compressed air is used for the cleaning of the elements filtranti to wear protections for the face and respirator, gloves and fit garments for such operations. For the operations of cleaning of the element filter of the air to make reference to the manual of instructions of the motor. Note: Filter can be clean for 5 time, then you have to change.

- 8.7.6 Controls and maintenance every 50 hours Substitution oil motor **Oil or warm parts can cause accidents. Don't bring oil or warm parts to contact with the skin.** To avoid problems with the motor to never overcome the maximum level of lubricating oil.

An excess of oil of the motor can provoke the breakup of it.

Never turn on the motor when the level of the oil overcomes the maximum inferior e/o to the least one. For the operations of substitution of the oil motor to make reference to the manual of instructions of the motor. Attenzione !! Ricordarsi sempre che l'olio e i filtri usati sono rifiuti speciali e come tali devono essere gestiti a termini di legge.

8.7.7 Cleaning fuel



Attention!!

The lost fuel on warm surfaces can provoke a fire.

Also the fuel is a special refusal to follow to the norms vigenti for the disposal of the residual liquids. For the operations of cleaning of the cup fuel to make reference to the manual of instructions of the motor.

8.7.8 Substitution filter air

For the operations of substitution element filtrante air to make reference to the manual of instructions of the motor.

8.7.9 Substitution of the machintridge of the filter hydraulic plant

The filter is located under the flatmachine of load. lift the flatcar and to extinguish the motor To loosen the cork loaded oil (1) for depressurizzare the circuit

To clean the zone to maintain the dirt to the outside of the body of the filter (2).

4. Position under a container suitable to the filter to pick up the possible spillages of oil that can be happened during the operations of substitution of thetridge filtrante. Note: always follow to the norms vigenti for a disposal of the exhausted oil and the used filters.

5. using a special key to unscrew the cartridge filter (3) turning counter clockwise in sense. To clean the body (2). **Note** The cartridge filter must have replaced. Riutilizzare is not possible one cartridge already used.

6. to apply some oil on the ring of estate (4) 7. to insert the new cartridge (3), to manually press in position, here to tighten with the special key of a turn. 8. to start the motor and to check the level of the hydraulic oil

9. you again pressurize the reservoir: After having completely wide the cylinder with the cork (1) open, to close again the cork of filling of the reservoir. 10. You check if there are losses from the cartridge (3)

8.7.10 Controls and maintenance every 500 hours



Substitution hydraulic oil

You contact with oil or warm parts you/they can provoke burns.

To temperature of exercise, the reservoir of the oil is warm and could be under pressure. To remove the cork of load oil (1) slowly so that to make to go out the pressure of the inside of the reservoir.

To remove only the cork of load oil to out motor and when the same is enough cold to be able him to remove barehanded.

1. Position the machine on plain ground with the cylinder of the completely wide large case.

2. Insert the sure one against the accidental lowering and to extinguish the motor.

3. Clean the zone to maintain the dirt to the outside of the reservoir.

4. Loosen the cork of load of the oil for depressurizzare the reservoir..

Remove the oil from the reservoir using a fit pump picking up him/it in a fit container to contain around 20Lt.

Note: to digest oil and filters used according to the normative .

5. To rinse the inside of the reservoir with clean oil..

6. To fill the reservoir with hydraulic oil. (For the choice of the proper oil to see chart paragraph 8.6).

7. to start the motor for a few minutes holding him/it to low regime of turns.

8. to operate the levers of control to do so that the whole hydraulic circuit begin full..

9. to bring the machine under the initial conditions and to extinguish the motor.

10. To check the level of the hydraulic oil and to add of it if necessary to maintain the suitable level on the level.

11. To pressurize the reservoir hydraulic oil; with the cylinder of the completely wide flatcar to remove and to put again to his/her place the cork of load.

To support the large case to the loom and switch off the motor.

8.7.11 Parking for a lot f time

• To store the machine for long time to perform the following procedure:

To " clean the machine and to store to the covered one. If it is had to store to the outside, to set the machine on a plain ground and to cover her/it.

To " apply fat on the parts exposed of the cylinder (stem), to fatten up all the pivots and the mobile parts.

• " During the storage to turn on once the machine a month to maintain the film of oil of lubrication. **If the machine is inside a store. To prevent the rust is good norm to have local ventilated.**

• **At the end of the storage:**

• **Remove the fat from the stem of the cylinder**

• **Make sure himself/herself/themselves some level of filling of the reservoirs of the fuel and the lubrication.**

9. Problems, probable causes, formality of intervention

PROBLEMS	PROBABLE CAUSES	FORMALITY OF INTERVENTION
Hard joy stick or that doesn't automatically return back	• Inefficient distributor.	• Ask for intervention assistance.
impossible any movement or it	• Oil hydraulic insufficient.	• Fill up to level

misses power	<ul style="list-style-type: none"> • Filter clogged oil. Lowering of the power of the motor. • Breakdown of the pump or the joint. • Defective control valve. 	<ul style="list-style-type: none"> • Perform maintenance filter oil. • perform maintenance I filter air and to check the feeding. • Ask for intervention assistance. • Ask for intervention assistance.. • Ask for intervention assistance..
The traction doesn't work on one or both the sides.	<ul style="list-style-type: none"> • An extraneous body as a stone, have been inserted. • Bad operation of the motor of traction. 	<p>Remove the inserted material.</p> <ul style="list-style-type: none"> • Ask for intervention assistance..
Lack power of lifting flatcar	<ul style="list-style-type: none"> • Lack hydraulic oil. • Damaged control valve.. Lack to hydraulic cylinder. 	<ul style="list-style-type: none"> • Fill up to the level.Ask for intervention assistance.. • Ask for intervention assistance..



For other non suitable problem list, to contact the Technical support staff.

ATTENTION!!!!!! WE DISCLAIM EVERY RESPONSIBILITY IN THE CASE IN WHICH THE MACHINE SUBMITTED IN MAINTENANCE ACCORDING TO THE PROCEDURES IS BROUGHT INDICATIONS AND IS NOT USED PARTS AND ORIGINAL ACCESSORIES.